



***OWNER'S/OPERATOR'S
MANUAL***



LANDFORCE 550

NOTE: A storage compartment has been provided on the ATV for keeping this manual with the vehicle. Please keep the manual in the storage compartment so it can be easily found and referred to when needed.



WARNING

Exhaust gases from this product contain chemicals known, in certain quantities, to cause cancer, birth defects or other reproductive harm.

CONTENTS

1. INTRODUCTION	1
2. UNDERSTANDING WARNINGS	5
3. SAFETY LABELS	7
4. PRE-RIDE INSPECTION	15
5. OPERATION WARNINGS	16
6. V.I.N. AND ENGINE SERIAL NUMBER	31
7. CONTROLS AND FUNCTIONS	33
8. STARTING THE ENGINE	55
9. VEHICLE BREAK-IN PERIOD	57
10. RIDING GEAR	58
11. CARRYING LOADS	60
12. DRIVING YOUR VEHICLE	62
13. CVT SYSTEM	75
14. BATTERY	77
15. EXHAUST SYSTEM	81
16. MAINTENANCE	83
17. TROUBLESHOOTING	104
18. TOOLS SUPPLIED WITH THE VEHICLE	110
19. SPECIFICATIONS	111

OWNER'S / OPERATOR'S MANUAL, October 2025

1. INTRODUCTION

Introduction

Congratulations on the purchase of your new Linhai All Terrain Vehicle. We are committed to delivering to you a product engineered and manufactured to the highest performance and quality standards. We are sure that you will enjoy superior levels of performance, reliability, riding comfort, and safety.

This manual is provided to help the owner and operators become familiar with the operation and features of this ATV. It also includes important information on the care and maintenance of your ATV.

Read this manual carefully. The information contained within, and the warning labels supplied with this product, will help keep you safe and ensure proper operation of your ATV.

Make sure you understand and follow all Warnings and Instructions in this manual.

Important Safety Notice

- Never perform any modifications to the engine, drive system, mechanical or electrical systems of your ATV. Never install aftermarket parts or accessories intended to increase the speed or power of your ATV.

- Failure to follow these warnings increases the possibility of accident leading to **DEATH** or **SERIOUS INJURY!**

- Additionally, failure to follow these requirements will void the Warranty on your ATV.

NOTE

Adding certain accessories, including, but not limited to, mowers, blades, sprayers, winches, and windshields, can affect the handling and performance of your ATV.

1. INTRODUCTION

Practice Responsible ATV Riding

Make sure that you understand and follow all local, state and national riding laws and requirements.

Remember.....Respect your vehicle, respect the environment and property of others. You are responsible for your safety and the safety of others around you when you ride!

AN ATV CAN BE HAZARDOUS TO OPERATE.

An ATV handles differently from other vehicles including motorcycles or cars. A collision rollover can occur quickly, even during routine maneuvers such as turning and driving on hills or over obstacles, if you fail to take proper precautions.



SERIOUS INJURY OR DEATH

can result if you do not follow these instructions.

- Read this manual and all warning labels carefully and follow the operating procedures described.
- Never operate an ATV without proper instruction. Take a training course. Beginners should receive training from a certified instructor. Contact an authorized ATV dealer to find out about the training courses nearest you.
- Never permit children under 16 years to operate this ATV. Read this manual and all product labels, and completed a certified training course, before operation.
- Always try to avoid operating this ATV on any paved surfaces, including sidewalks, driveways, parking lots and streets.
- Never operate an ATV without wearing an approved helmet that fits properly. You should also wear eye protection (goggles or face shield), gloves, ankle boots, long-sleeved shirt or jacket, and long pants.
- Never consume alcohol or drugs before or while operating this ATV.
- Never operate at excessive speeds. Always travel at a speed which is proper for the terrain, visibility, operating conditions, and your experience.
- Never attempt wheelies, jumps or other stunts.
- Always inspect your ATV each time you use it to make sure it is in safe operating condition, always follow the inspection and maintenance procedures and schedules described in this manual.

1. INTRODUCTION

- Always keep both hands on the handlebars and both feet on the footrests of the ATV during operation.
- Always go slowly and be extra careful when operating in unfamiliar terrain. Always be alert to changing terrain conditions when operating the ATV.
- Never operate on excessively rough, slippery or loose terrain.
- Always follow proper procedures for turning as described in this manual. Practice turning at low speeds before attempting to turn at faster speeds. Do not turn at excessive speed.
- Always have the ATV checked by an authorized dealer if it has been involved in an accident.
- Never operate ATV on hills too steep for the ATV or for your abilities. Practice on smaller hills before attempting larger hills.
- Always follow proper procedures for climbing hills as described in this manual. Check the terrain carefully before you start up any hill. Never climb hills with excessively slippery or loose surface. Shift your weight forward. Never open throttle suddenly. Never go over the top of any hill at high speed.
- Always follow proper procedures for going down the hills and for braking on hills as described in this manual. Check the terrain carefully before you go down any hill. Shift your weight backward. Never go down a hill at high speed. Avoid crossing a hill at an angle which would cause the vehicle to lean sharply to one side. Go straight down the hill if possible.
- Always follow proper technique of crossing the side of a hill (Traversing a slope) as described in this manual. Avoid hills with excessively slippery or loose surfaces. Shift your weight to the up side of the ATV. Never try to turn the ATV around on any hill until you have mastered the turning technique described in this manual on level ground. Avoid crossing the side of a steep hill if possible.
- Always use proper procedures if you stall or roll backwards when climbing a hill. To avoid stalling, maintain a steady speed when climbing a hill. If you stall or roll backwards, follow the special procedure for braking described in this manual. Dismount on the uphill side or to either side if pointed straight uphill. Turn the ATV around and remount, following the procedure described in this manual.

1. INTRODUCTION

- Always check for obstacles before operating in a new area. Never attempt to operate over large obstacles, such as large rocks or fallen trees. Always follow proper procedures when operating over obstacles as described in this manual.
- Always be careful of skidding or sliding. On slippery surfaces, such as ice, go slowly and be very cautious in order to reduce the chance of skidding or sliding out of control.
- Avoid operating the ATV through deep or fast flowing water. Avoid water which exceeds the recommended maximum depth, go slowly, balance your weight carefully avoiding sudden movements, maintain a slow and steady forward motion, do not make sudden turns or stops, and do not make sudden throttle changes.
- Wet brakes may reduce the stopping ability. Test your brakes after leaving the water. If necessary, apply brakes lightly several times to let friction dry out the brake pads and the linings.
- Always use the size and type of tires specified in this manual. Always maintain proper tire pressure as described in this manual.
- Never modify an ATV through improper installation or use of accessories
- Never exceed the maximum load capacity of this ATV.

2. UNDERSTANDING WARNINGS

ATTENTION!

THIS VEHICLE IS NOT A TOY. This vehicle is ONLY for the riders who are 16 years old or more. BEFORE OPERATION, PARENTS AND CHILDREN MUST READ AND UNDERSTAND WARNINGS AND SAFETY PRECAUTIONS IN THIS MANUAL.



GET TO KNOW YOUR VEHICLE BEFORE YOU DRIVE IT!

Read this manual thoroughly before operating this vehicle. Operating this vehicle comes with responsibilities for your own safety, the safety of others, and environmental protection.

Disclaimer:

The images in this manual are for illustration purposes only, and may not be an exact representation of the product. Your model may differ.

2. UNDERSTANDING WARNINGS

SAFETY ALERT

WARNINGS identify special instructions or procedures which, if not correctly followed, could result in personal injury or death. Read all **WARNINGS** in this manual carefully and follow the instructions to stay safe.

The following safety signal words are used in this manual to highlight important safety information:



Safety Alert Symbol.

This symbol alerts you to potential hazards that could result in personal injury. Pay attention whenever you see it on the vehicle or in the manual. Your safety is involved!



WARNING

Indicates a potential hazard which could result in severe injury or death.



DANGER

Indicates a potential hazard which may result in minor personal injury or damage to the ATV.



CAUTION

Indicates a situation that can result in damage to the machine.

NOTE A **NOTE** provides key information to make procedure easier or clearer.

3. SAFETY LABELS

Safety labels and their locations

Warning labels have been placed on the ATV for your protection. It is essential to read and follow the instructions on each label carefully, because they highlight specific hazards and precautions that must be observed to prevent personal injury, damage or death.

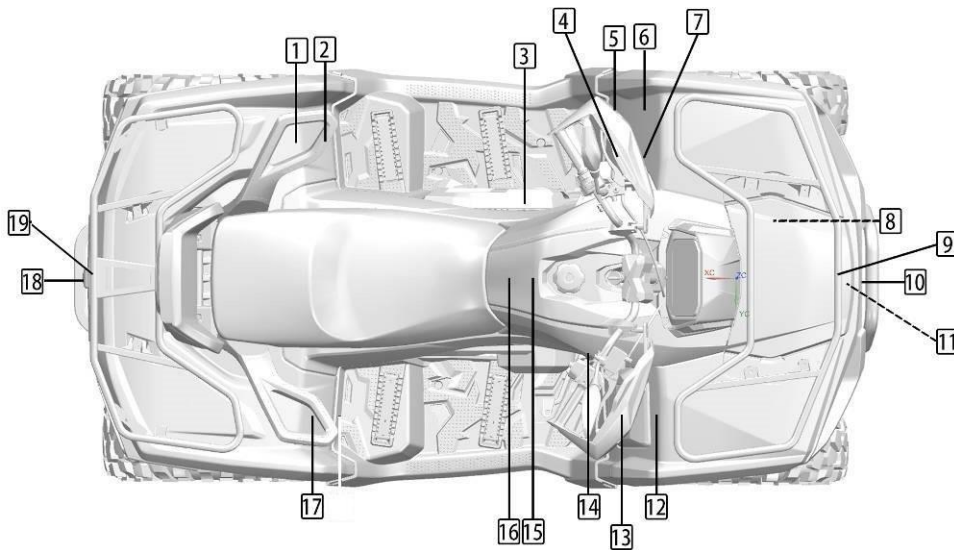

Always ensure that all labels are legible and intact, and never remove or cover them.

If a label becomes illegible or comes off, contact your Linhai dealer to purchase a replacement.

3. SAFETY LABELS

1.

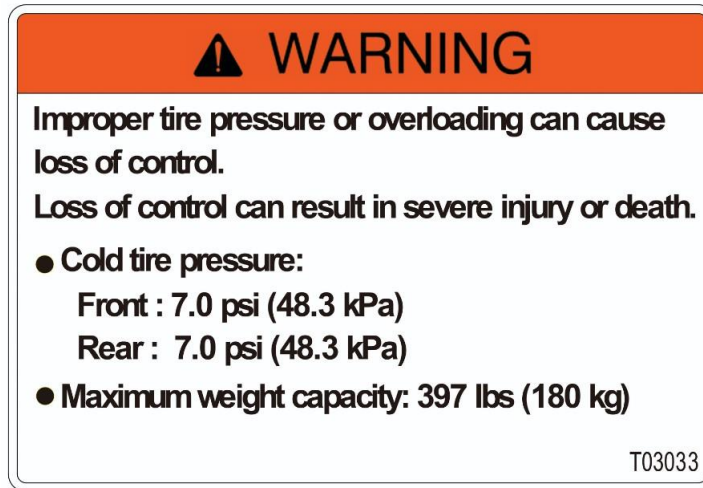

2.



3. SAFETY LABELS

3.



4.



5.



3. SAFETY LABELS

6.

⚠ WARNING

Improper ATV use can result in SEVERE INJURY or DEATH

		
ALWAYS USE AN APPROVED HELMET AND PROTECTIVE GEAR	NEVER CARRY MORE THAN ONE PASSENGER	NEVER USE WITH DRUGS OR ALCOHOL

NEVER carry a passenger too small to firmly plant feet on footrests and securely grasp hand holds.

THE PASSENGER MUST ALWAYS:

- use an approved helmet and protective gear
- securely grasp hand holds and plant feet firmly on footrests while seated in the passenger seat
- tell operator to slow down or stop if uncomfortable -get off and walk if conditions require

NEVER operate:

- without proper training or instruction
- at speeds too fast for your skills or the conditions

ALWAYS:

- use proper riding techniques to avoid vehicle overturns on hills and rough terrain and in turns

**LOCATE AND READ OWNER'S MANUAL.
FOLLOW ALL INSTRUCTIONS AND WARNINGS.**

T03034

7.

NOTE

Check engine oil every 500 kilometers (310 miles)

T02744

3. SAFETY LABELS

8.

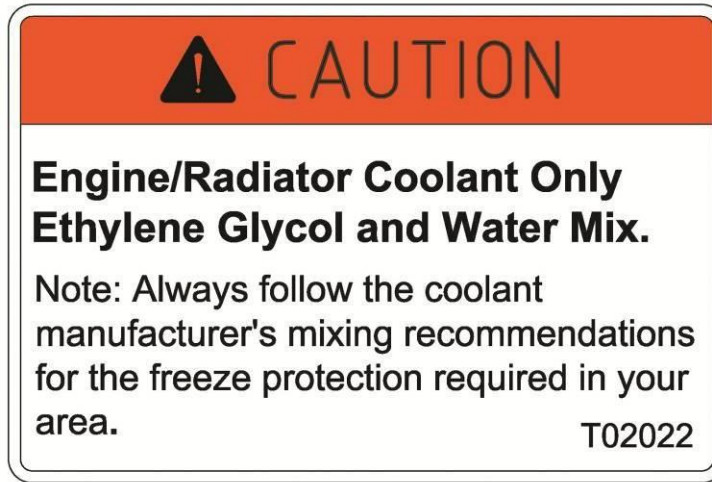

9.



10.

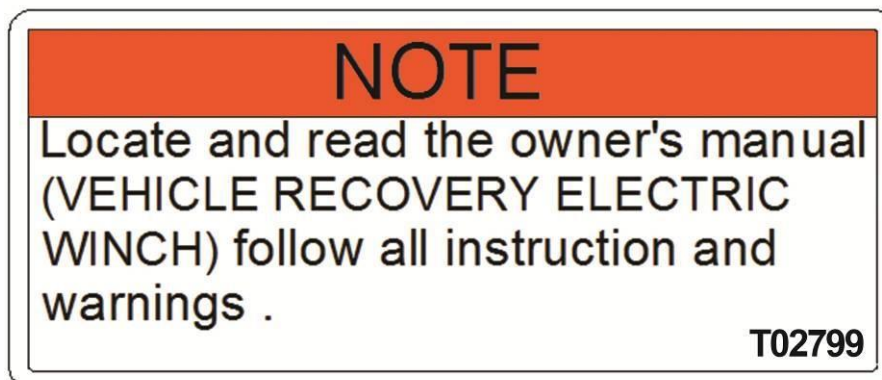

3. SAFETY LABELS

11.

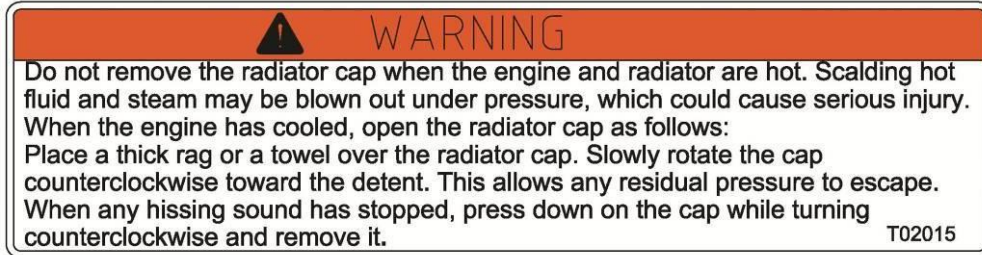

12.

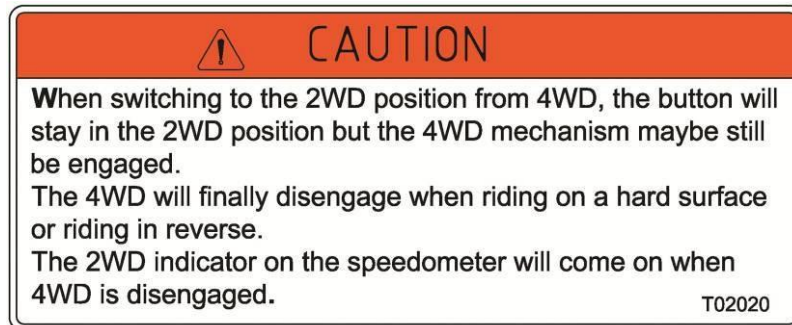

13.

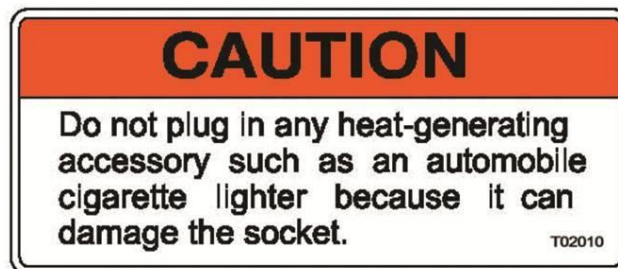

3. SAFETY LABELS

14.



15.



16.

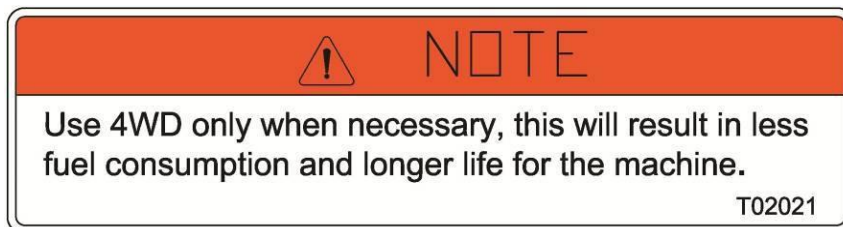

3. SAFETY LABELS

17.

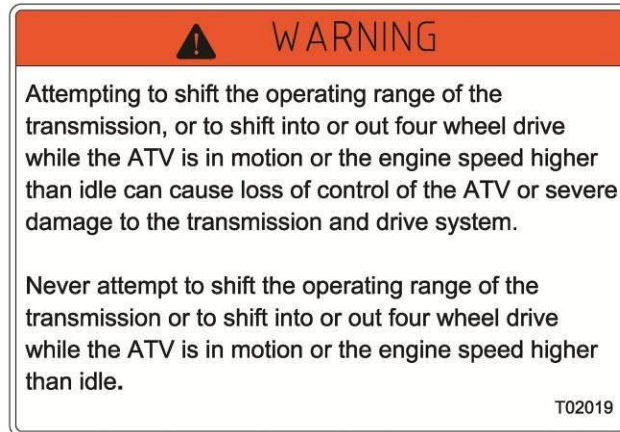

18.

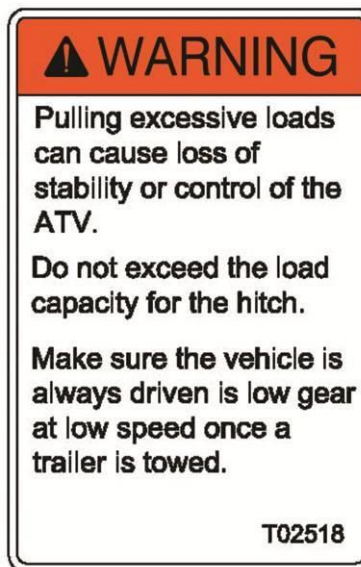

19.

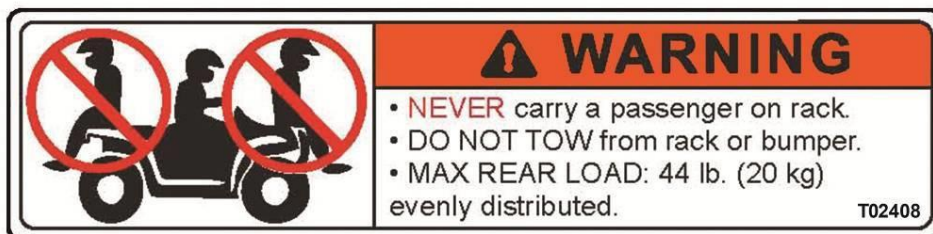

4. PRE-RIDE INSPECTION



WARNING

Inspect your ATV each time before riding to ensure it is in proper working order. If proper inspection is not done, severe injury or death could result.

Use the following checklist to verify your machine is in proper working order each time you ride.

ITEM/ INSPECTION PROCEDURE

1. **Tires** — check condition and pressures.
 2. **Fuel tank**— check for leaks, fill the fuel tank to the proper level.
 3. **Brakes** — check fluid level, operation, adjust (including parking brake).
 4. **Throttle**— check for free operation, smooth closing and free play.
 5. **Headlights / Taillights / Brake lights**— check operation of all lights and switches, including indicator lights.
 6. **Engine Stop Switch**— check for proper function.
 7. **Wheels**— check for tightness of wheel nuts and axle nuts; check if axle nuts are secured by cotter pins.
 8. **Air cleaner element**— inspect; clean or replace
 9. **Steering**— check for proper function and abnormal free play.
 10. **Loose parts** — visually inspect vehicle for any damaged components or loose nuts/bolts / fasteners.
 11. **Operator's and passenger's helmets, goggles and clothing.**
 - check if everybody on board has helmets in right size, eye protection (goggles or face shield) and proper clothing.
-

5. OPERATION WARNINGS

Mounting and Dismounting the ATV

Mounting the ATV

Mount the ATV from the left or right side using the designated floorboards.

Dismounting the ATV

Before dismounting, check that the area is safe.

Bring the ATV to a complete stop and park it on level ground.

Turn off the engine (key OFF) and shift the transmission into the N position.

Firmly apply the left-hand brake lever, engage the parking brake, and make sure the vehicle is parked.

Dismount using the left or right floorboards.



WARNING

POTENTIAL HAZARD

Operating this ATV without proper instructions.

WHAT CAN HAPPEN

The risk of an accident is greatly increased if operator does not know how to operate the ATV properly in different situations and on different types of terrain.

HOW TO AVOID THE HAZARD

Beginners and inexperienced operators should complete the certified training course. They should then regularly practice the skills learned in the course, as well as the operating techniques described in this Manual.

For more information about training courses contact your ATV dealer.



WARNING

POTENTIAL HAZARD

Operating this ATV without wearing an approved helmet, eye protection and protective clothing.

WHAT CAN HAPPEN

Operating this ATV without an approved helmet greatly increases the risk of severe head injury or death in the event of an accident.

5. OPERATION WARNINGS

Operating without eye protection can result in an accident and increases risk of a severe eye injury in the event of an accident.

HOW TO AVOID THE HAZARD

Always wear an approved helmet which fits properly.

Also wear eye protection (goggles or face shield); gloves; boots; long-sleeved shirt or jacket; and long pants.



WARNING

POTENTIAL HAZARD

Operating this ATV after consuming alcohol or drugs.

WHAT CAN HAPPEN

Seriously impair your judgment

Slow your reaction time

Affect your coordination and awareness

Lead to a serious or fatal accident

HOW TO AVOID THE HAZARD

Never consume alcohol or drugs before or while driving this ATV.



WARNING

POTENTIAL HAZARD

Operating this ATV at excessive speeds.

WHAT CAN HAPPEN

Increases your chances of losing control of the ATV, which can result in an accident.

HOW TO AVOID THE HAZARD

Always travel at a speed which is proper for the terrain, visibility and operating conditions; and your experience.

5. OPERATION WARNINGS



WARNING

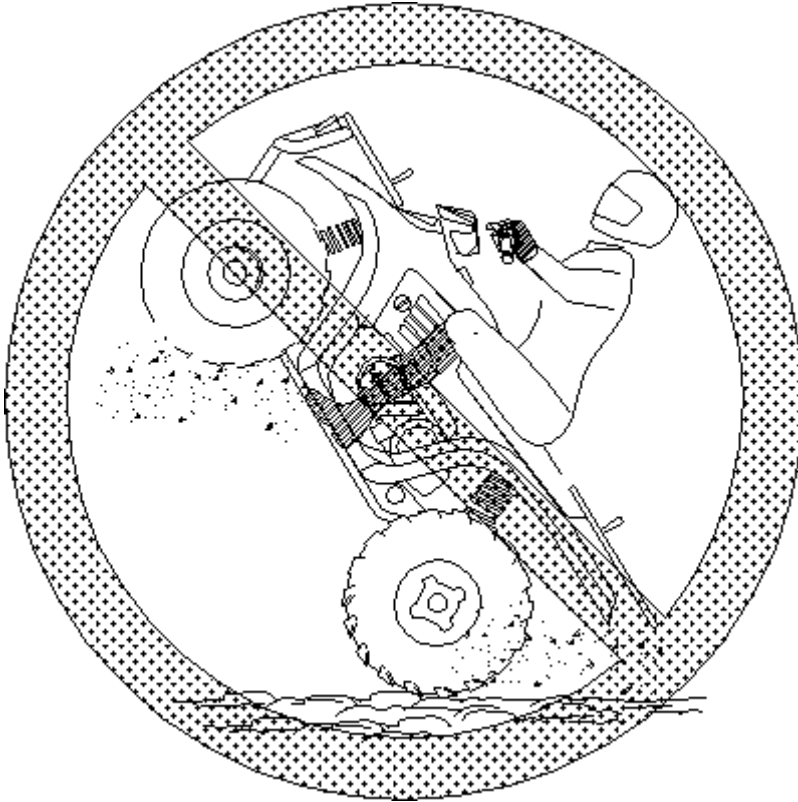

POTENTIAL HAZARD

Performing wheelies, jumps and other stunts.

WHAT CAN HAPPEN

Increases the chance of an accident, including an overturn.

HOW TO AVOID THE HAZARD

Never attempt stunts, such as wheelies or jumps.

5. OPERATION WARNINGS



WARNING

POTENTIAL HAZARD

Failure to inspect the ATV before operating.

WHAT CAN HAPPEN

Increases the possibility of an accident or equipment damage.

HOW TO AVOID THE HAZARD

Always inspect your ATV each time you use it to make sure the ATV is in safe operating condition.

Always follow the inspection and maintenance procedures and schedules described in this Manual.



WARNING

POTENTIAL HAZARD

Removing hands from handlebars or feet from footrests during operation.

WHAT CAN HAPPEN

Removing even one hand or one foot can reduce your ability to control the ATV, and could cause you to lose your balance and fall off the ATV. If you remove a foot from the footrest, your foot or leg may come into contact with the rear wheels, which could lead to injury or cause an accident.

HOW TO AVOID THE HAZARD

Always keep both hands on the handlebars and both feet on the footrests during operation.

5. OPERATION WARNINGS



WARNING

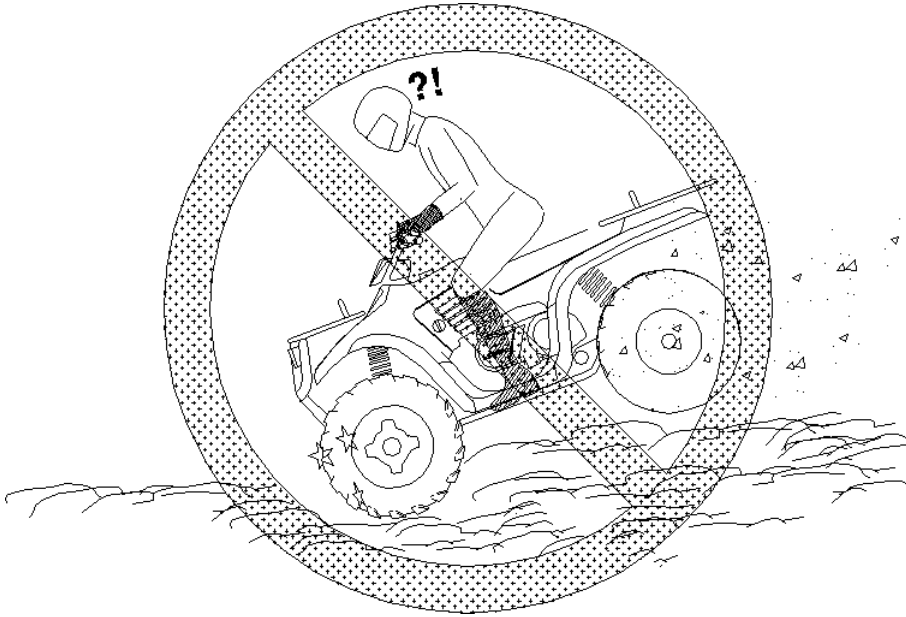

POTENTIAL HAZARD

Failure to use extra care when operating the ATV on unfamiliar terrain.

WHAT CAN HAPPEN

You can come upon hidden rocks, bumps, or holes, without enough time to react.

Could result in the ATV overturning or going out of control.

HOW TO AVOID THE HAZARD

Go slowly and be extra careful when operating on unfamiliar terrain.

Always be alert to changing terrain conditions when operating the ATV.



WARNING

POTENTIAL HAZARD

Failure to use extra care when operating on excessively rough, slippery or loose terrain.

5. OPERATION WARNINGS

WHAT CAN HAPPEN

Could cause loss of traction or vehicle control, which could result in an accident, including an overturn.

HOW TO AVOID THE HAZARD

Do not operate on excessively rough, slippery or loose terrain until you have learned and practiced the skills necessary to control the ATV on such terrain.

Always be especially careful when riding on these kinds of terrain.



WARNING

POTENTIAL HAZARD

Climbing hills improperly.

WHAT CAN HAPPEN

Could cause loss of control or cause ATV to overturn.

HOW TO AVOID THE HAZARD

Always follow proper procedures for climbing the hills as described in this manual.

Always check the terrain carefully before you start up any hill.

Never climb hills with excessively slippery or loose surfaces.

Shift your weight forward.

Never open the throttle suddenly, the ATV could flip over backwards.

Never go over the top of any hill at high speed. An obstacle, a drop, another vehicle or person could be on the other side.



WARNING

POTENTIAL HAZARD

Turning improperly.

WHAT CAN HAPPEN

ATV could go out of control, causing a collision or overturn.

HOW TO AVOID THE HAZARD

Always follow proper procedures for turning as described in this Manual.

5. OPERATION WARNINGS



WARNING

POTENTIAL HAZARD

Operating on excessively steep hills.

WHAT CAN HAPPEN

The vehicle can overturn more easily on extremely steep hills than on small hills or level surfaces.

HOW TO AVOID THE HAZARD

Never operate the ATV on hills too steep for the ATV or for your abilities.

Practice on smaller hills before attempting large hills.

Never operate the ATV on hills steeper than 18%.



WARNING

POTENTIAL HAZARD

Going down a hill improperly.

WHAT CAN HAPPEN

Could cause loss of control or cause ATV to overturn.

HOW TO AVOID THE HAZARD

Always follow proper procedures for going down hills as described in this Manual. NOTE: A special technique is required when braking if you go downhill.

Always check the terrain carefully before you start down any hill.

Shift your weight backwards.

Never go down a hill at high speed.

Avoid going down a hill at an angle which would cause the vehicle to lean sharply to one side. Go straight down the hill where possible.



WARNING

POTENTIAL HAZARD

Improperly crossing the side of a hill or turning on hills.

WHAT CAN HAPPEN

Could cause loss of control or cause ATV to overturn.

HOW TO AVOID THE HAZARD

Never attempt to turn the ATV around on any hill until you have

5. OPERATION WARNINGS

mastered the turning technique as described in this Manual on level ground. Be very careful then turning on any hill.

Avoid crossing the side of a steep hill if possible.

When crossing the side of a hill:

Always follow proper procedures as described in this Manual. Avoid hills with excessively slippery or loose surfaces.

Shift your weight to the uphill side of the ATV.



WARNING

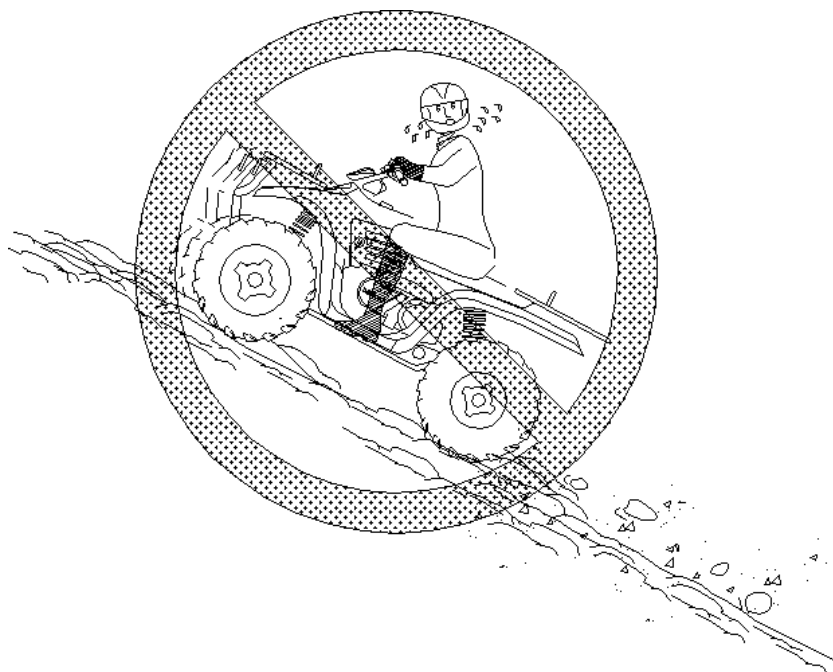

POTENTIAL HAZARD

Stalling, rolling backwards or improperly dismounting while climbing a hill.

WHAT CAN HAPPEN

Could result in ATV overturning.

HOW TO AVOID THE HAZARD

Maintain steady speed when climbing a hill.

If you lose all forward speed:

- Keep your body weight uphill.

- Apply the brakes.

- Lock parking brake after you are stopped.

5. OPERATION WARNINGS

If you begin rolling backwards:

Keep weight uphill.

Never apply the throttle.

Never apply the rear brake when rolling backwards.

Apply the front brake gradually.

When fully stopped, apply rear brake as well, and then lock the parking brake.

Get off the ATV on the uphill side, or to either side when pointing directly uphill.

Turn the ATV around and remount following the procedure described in this Manual.



WARNING

POTENTIAL HAZARD

Improperly operating over obstacles.

WHAT CAN HAPPEN

Could cause loss of control or a collision. Could cause the ATV to overturn.

HOW TO AVOID THE HAZARD

Before operating in a new area, check for obstacles.

Use extreme caution when riding over large obstacles, such as large rocks or fallen trees.

If you cannot avoid obstacles, always follow proper procedures as described in this manual.



WARNING

POTENTIAL HAZARD

Skidding or sliding,

WHAT CAN HAPPEN

You may lose control of the ATV.

You may also regain traction unexpectedly, which may cause the ATV to overturn.

HOW TO AVOID THE HAZARD

On slippery surfaces, such as ice, go slowly and be very cautious in order to reduce the chance of skidding or sliding out of control.

5. OPERATION WARNINGS



WARNING

POTENTIAL HAZARD

Operating this ATV through deep or fast flowing water.

WHAT CAN HAPPEN

Tires may float, causing loss of traction and loss of control, which could lead to an accident.

HOW TO AVOID THE HAZARD

Never operating the ATV through water which exceeds the recommended maximum depth in this manual.

Avoid operating the ATV through deep or fast flowing water. If you cannot avoid water, go slowly, balance your weight carefully avoiding sudden turns or stops, and do not make sudden throttle changes.

Remember that wet brakes may have reduced stopping ability.

Test your brakes after leaving water. If necessary, apply them several times to let friction dry out the pads.



WARNING

POTENTIAL HAZARD

Operating this ATV with improper tires, or with improper or uneven tire pressure.

WHAT CAN HAPPEN

Use of improper tires on this ATV, or operation of this ATV with improper or uneven tire pressure, may cause loss of control, and increases the risk of an accident.

HOW TO AVOID THE HAZARD

Always use the size and type tires specified in this manual for this vehicle.

Always maintain proper tire pressure as described in this manual.



WARNING

POTENTIAL HAZARD

Operating this ATV with improper modifications.

WHAT CAN HAPPEN

Improper installation of accessories or modification of this vehicle may cause

5. OPERATION WARNINGS

changes in handling which in some situations could lead to an accident.

5. OPERATION WARNINGS

HOW TO AVOID THE HAZARD

Never modify this ATV through improper installation or use of accessories. All parts and accessories added to this vehicle should be genuine or equivalent components designed for use on this ATV; and should be installed and used according to instructions. If you have questions, consult an authorized dealer.



WARNING

POTENTIAL HAZARD

Overloading the ATV or carrying or towing cargo.

WHAT CAN HAPPEN

Could cause changes in vehicle handling which could lead to an accident.

HOW TO AVOID THE HAZARD

Never carry or tow cargo, or carry more than one passenger.



WARNING

POTENTIAL HAZARD

Riding on frozen lakes and rivers.

WHAT CAN HAPPEN

Severe injury or death can result if the ATV and /or the operator break through the ice.

HOW TO AVOID THE HAZARD

Never ride you ATV on a frozen body of water.



WARNING

After a rollover or an accident, have a qualified Linhai service check the complete machine including, but not limited to, brakes, throttle and steering for possible damage.

5. OPERATION WARNINGS



WARNING

Safe operation of this ride-active vehicle requires good judgment and physical skills. Persons with cognitive or physical disabilities who operate this vehicle have an increased risk of overturns and loss of control which could result in severe injury or death.



WARNING

Keep combustible materials away from exhaust system. Fire may result.

5. OPERATION WARNINGS

DRIVING THROUGH WATER

NOTICE

Major engine damage can result if the vehicle is not thoroughly inspected after operation in water. Perform the services outlined in the Maintenance chapter. The following areas need special attention: engine oil, transmission oil, demand drive fluid and all grease fittings. If the vehicle tips or overturns in water, or if the engine stops during or after operating in water, service is required before starting the engine. Your dealer can provide this service. If it's impossible to bring the vehicle in before starting the engine, perform the service outlined in the Vehicle Immersion section of this manual, and take the vehicle in for service at the first opportunity.

Your ATV can operate through water **with a maximum recommended depth equal to the bottom of the footrests.**

Follow these procedures when operating through water:

1. Determine water depth and current before entering water.
2. Choose a crossing where both banks have gradual inclines.
3. Avoid operating through deep or fast-flowing water.
4. After leaving the water, test the brakes. Apply them lightly several times while driving slowly. The friction will help dry out the pads.



If it's unavoidable to enter water deeper than the footrest level:

- Proceed slowly. Avoid rocks and obstacles.
- Balance your weight carefully. Avoid sudden movements. Maintain a steady rate of speed. Do not make sudden turns or stops. Do not make sudden throttle changes

5. OPERATION WARNINGS



WARNING

TOWING HITCH



Cautions when installing the implement or dragging the ATV:

1. When installing the dragging implement / trailer, the engine should be stopped and the ATV should park at the flat safety place. Please read implement's or trailer's installing instructions, warning labels and operating manuals carefully before changing the implement.
2. Operation must follow the instructions in the operating manual. Do not operate the ATV with the implement attached or trailer connected until installation is fully completed.
3. When connecting a dragging implement or trailer to the ATV, personal injury may occur if the operator lacks the necessary experience. Seek assistance from a qualified professional when needed.
4. The implement must be lowered to the ground before dismounting the ATV.
5. All persons should keep clear of the area between the ATV and trailer while the ATV is in operation.

Front loader and/or backhoe cannot be attached.

This ATV is not applicable to "forestry application" and "work with crop sprayers".

DANGER!

This ATV is not designed for use with front-mounted implements such as a front loader, front dozer. Do not operate the ATV with such front mounted implements.



WARNING

JACKING POINTS

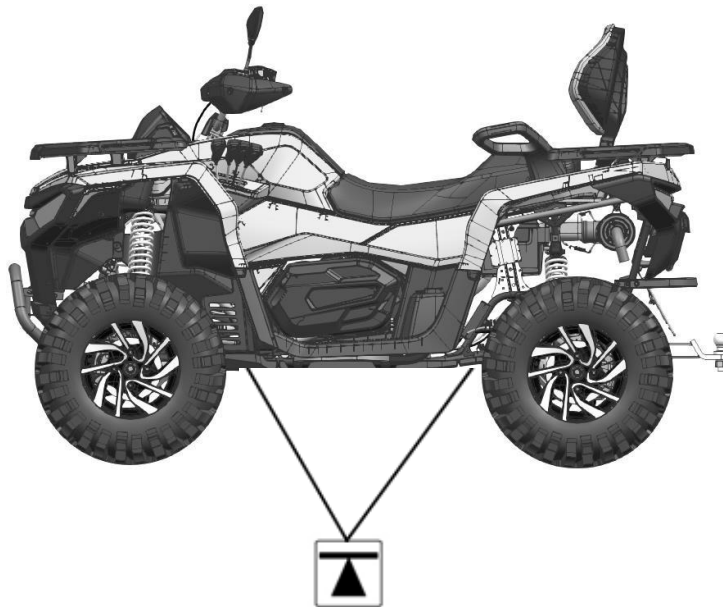

Recommended jacking points are indicated by this symbol  .

6. V.I.N. AND ENGINE SERIAL NUMBER

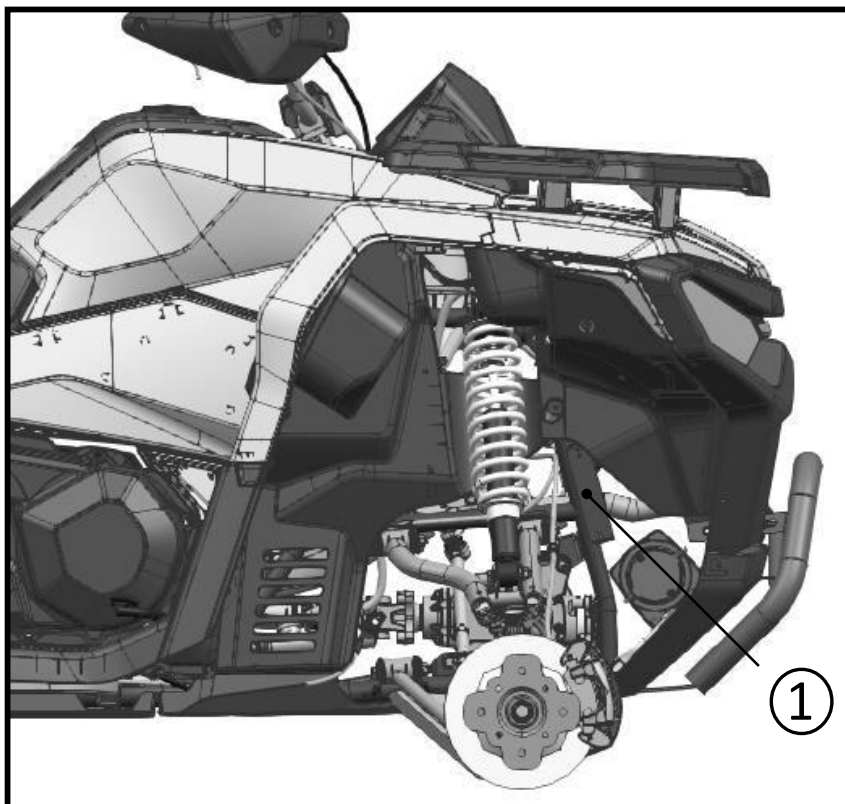

① VIN Number

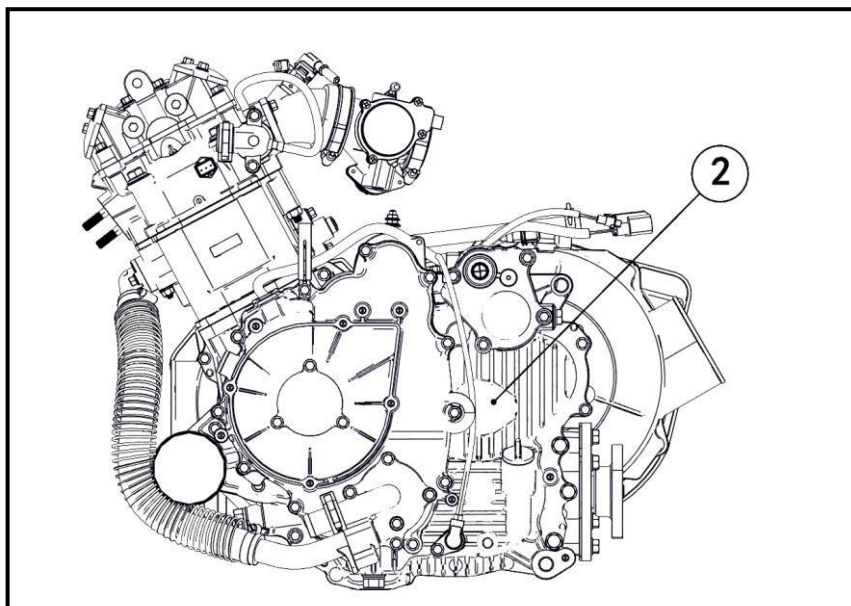

② Engine Serial Number

6. V.I.N. AND ENGINE SERIAL NUMBER

Record these numbers from your ATV in the spaces provided.

1. VIN Number (on the right side of front vertical beam of the frame.)

--	--	--	--	--	--	--	--	--	--	--	--	--	--	--	--	--	--

2. Engine Serial Number (on the left side of crankcase)

--

The vehicle frame and engine serial numbers are important for model identification when registering your vehicle, obtaining insurance or whenever replacement parts are required. In the event your vehicle were stolen these numbers are essential to the recovery and identification of your ATV.

Record Key Number

Remove the spare ignition key and store it in a safe place. Your key can be duplicated only by ordering a blank key and having it cut by mating it with your existing key.

6. V.I.N. AND ENGINE SERIAL NUMBER

ELECTRICAL SWITCHES

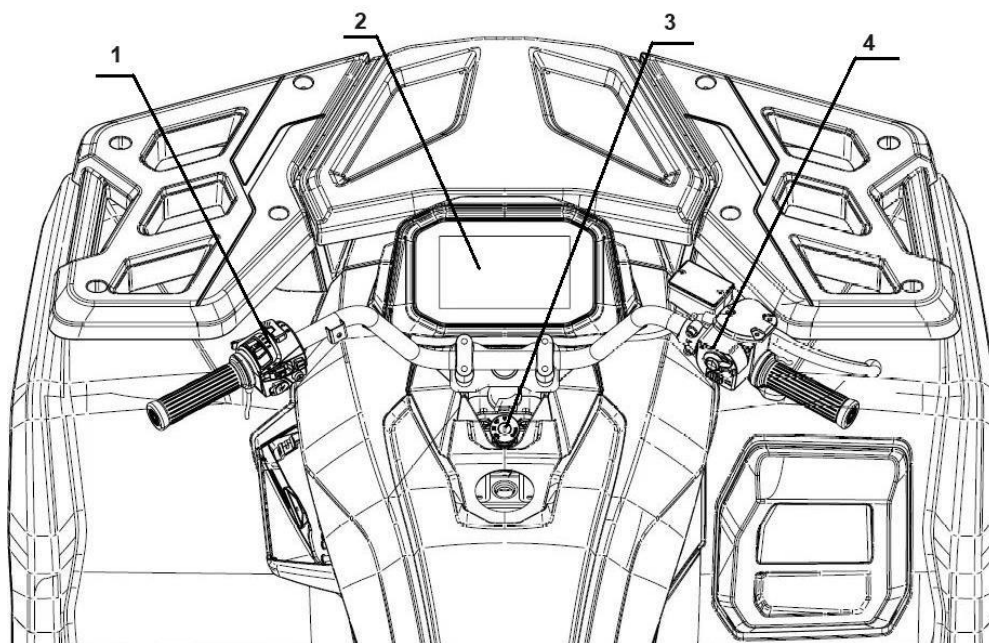

1. Left Handlebar Switches

2. TFT display

3. Main Switch

4. 2WD/4WD Switch and throttle lever

7. CONTROLS AND FUNCTIONS

Left Handlebar Switches

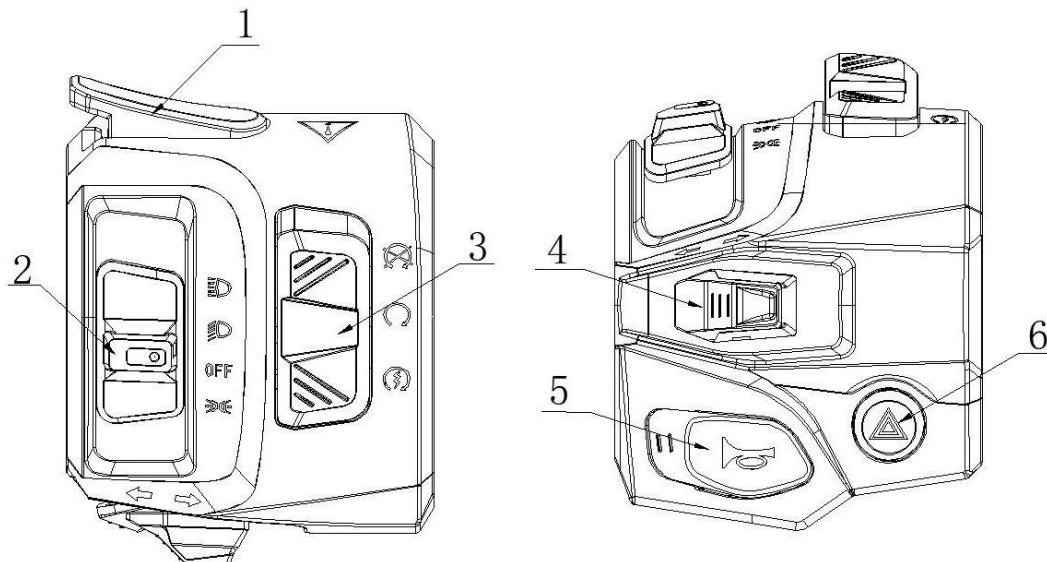

1. Override Button

The engine is normally limited when operating in 4WD/F-LOCK. If conditions require more engine power in 4WD/F-LOCK:

- Release the throttle, then press and hold the Override button ① to cancel the speed limiting function. While this button is depressed, the override indicator light will be illuminated.
- Releasing the button restores the speed limiting function.

The override button also allows you to increase the wheel speed when operating in reverse. To increase wheel speed when reversing, release the throttle and press the override switch.



WARNING

When the vehicle is in speed limiter mode, and the throttle is open, do not press the override button! Pressing the override button while the throttle is open can cause loss of control, severe injury or death. Always release the throttle before pressing the override button.

7. CONTROLS AND FUNCTIONS

2. Headlights Switch

The headlights switch has four positions:

 - Hi beam, front position lights, tail lights and license plate light are on.

 - Low beam, front position lights, tail lights and license plate light are on.

OFF - All lights are off.

 - Tail lights, front position lights and license plate light are on.



CAUTION



Avoid using the headlights for more than 15 minutes when the engine is off, as this may drain the battery and the starter motor may not be able to start the engine.

3. Engine Stop Switch and Starter Switch

When the switch is in  position, the engine is off.

When the switch is in  position, the engine can be started.

When the main switch is turned to ON, and the Engine Stop Switch is in

 position, push Starter button  to start the engine.



CAUTION

Do not operate the electric starter continuously for more than 5 seconds, or starter damage could occur. Wait at least 5 seconds between each attempt to start the engine to let the electric starter cool down. Do not push Starter button “ ” when the engine is running, or damage to the electric starter can result.

4. Turn Switch

Move the switch to  to turn on the left turn signals on.

Move the switch to  to turn on the right turn signals on.

5. Horn Button

Press the  button, the horn will sound.

7. CONTROLS AND FUNCTIONS

6. Hazard Switch

To activate the hazard lights, press the  button. The front and rear turn lights and the turn indicators on the display will flash. (Key must be in the ON position.)

Use this switch in an emergency, when:

- Temporary parking the vehicle in traffic
- The vehicle has failure.
- Low visibility conditions (e.g. fog, heavy rain)
- Unexpected road obstacles or accidents
- In other emergency situations requiring increased visibility to others.

7. CONTROLS AND FUNCTIONS

TFT display / Instrument Cluster

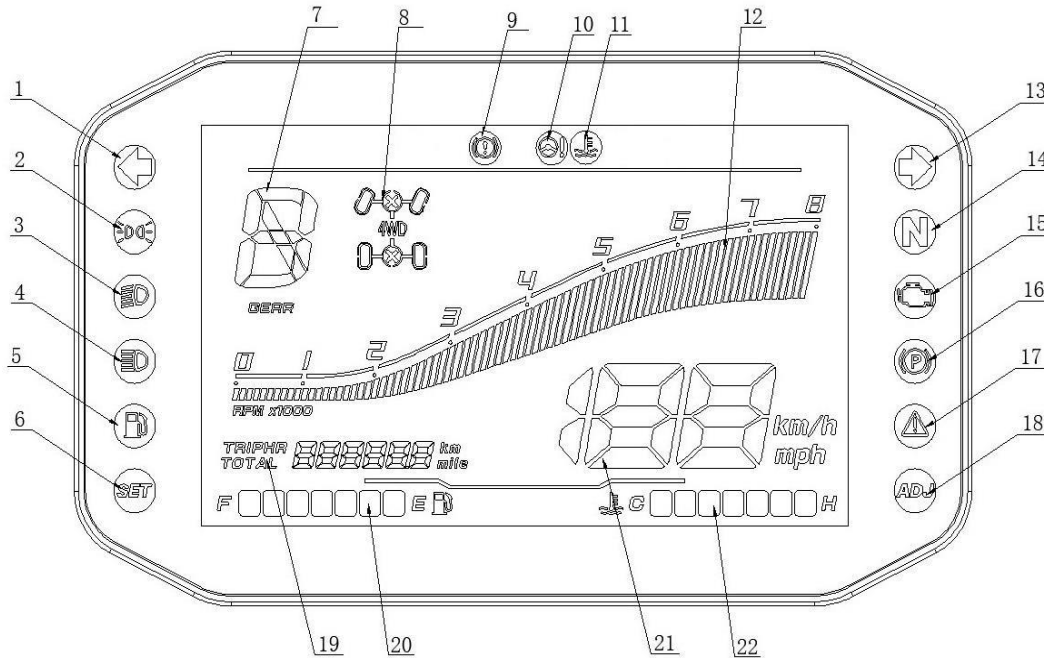

1	Left Turn Signal Indicator (Green)	12	Engine RPM meter
2	Position light indicator (Green)	13	Right Turn Signal indicator (Green)
3	Low beam indicator (Green)	14	Neutral position indicator (Green)
4	High beam indicator (Blue)	15	Engine warning light (Yellow)
5	Low fuel level warning (Yellow)	16	Parking brake indicator (Red)
6	SET - Select button	17	Override indicator
7	Gear position indicator	18	ADJ - Adjust button
8	Drive mode	19	ODO/trip/hour/fault code
9	Brake fluid level indicator	20	Fuel level (red)
10	EPS warning lamp (if equipped)	21	Speedometer
11	Coolant temp. warning lamp	22	Coolant temperature gauge

1. Left Turn Signal indicator (green)

When the flasher switch is turned to the left, the left turn signal lights and left turn signal indicator will flash.

2. Position light indicator (green)

This indicator illuminates when the light switch is turned to position lights.

7. CONTROLS AND FUNCTIONS

3. Low beam indicator (green)

This indicator illuminates when the headlight switch is turned to low beam position.

4. High beam indicator (blue)

This indicator illuminates when the headlight switch is turned to high beam position.

5. Fuel level warning indicator (yellow)

This indicator illuminates when the fuel level is low.

6. SET - Select button

Use in combination with the “ADJ” button to change dashboard settings. Short press the “SET” button to switch between “TOTAL”, “TRIP”, Engine hours, and Fault Code.

7. Gear position indicator

Displays the current gear position: L, H, N, R.

8. Drive mode

Display the current drive mode. There are three drive modes available: 2WD, 4WD and 4WD/F-LOCK. If the selected drive mode is not properly engaged, this indicator will flash.

9. Brake fluid level indicator

This indicator lights up when brake fluid level is low. Add DOT4 brake fluid and contact your dealer. Low brake fluid level may lead to air bubbles in the brake system, causing brake system malfunction and lead to serious accident.

10. EPS warning lamp (if equipped)

This indicator lights up when a malfunction occurs in the Electronic Power Steering system. Recommend to stop the vehicle and contact your dealer for inspection and repair. Continuing to operate could lead to permanent EPS damage. Also, malfunction in the EPS system leads to increased steering force.

11. Coolant temperature warning indicator

Both excessively low and excessively high coolant temperatures are harmful.

7. CONTROLS AND FUNCTIONS

Idle the engine to warm it up when it's too cold, stop the vehicle if the engine is too hot to prevent overheating. Always keep the coolant temperature within the safe range.

12. Engine RPM meter

Displays the current engine speed in RPM (Revolutions per minute).

13. Right Turn Signal indicator (green)

When the flasher switch is turned to the right, the right turn signal lights and right turn signal indicator will flash.

14. Neutral position indicator (green)

This indicator lights up when the transmission is in neutral.

15. Engine warning light (yellow)

This indicator lights up when a fault occurs in the EFI system. Please stop the vehicle and contact your dealer, as this may result in serious engine damage.



WARNING

When the ignition key is turned on but the engine is not started, the engine warning light should come on. After the engine starts, the light should go off. If either of the following conditions occurs, contact your Linhai dealer immediately to prevent possible vehicle damage:

1. Engine warning light stays on or flashes while the engine is running.
2. Engine warning light does not come on when the ignition is turned On and the engine is not running.

16. Parking brake indicator (red)

This indicator lights up when parking brake is activated.

17. Override indicator

When the Override button is pressed, this indicator lights up. In this state, the 4WD/F-LOCK speed limiter or reverse speed limiter are temporarily disabled.

18. ADJ - Adjust button

Use this button in combination with the "SET" button to change settings on the dashboard.

7. CONTROLS AND FUNCTIONS

Press and hold the “ADJ” button while in the TRIP mode to reset the trip distance to zero. Short press the “ADJ” button to switch between “km”, “km/h”, “miles”, and “mph”.

19. ODO/Trip/Fault Code

Default display shows the total mileage the vehicle has traveled. Press “SET” button to toggle between TRIP meter, engine hours and fault codes.

20. Fuel level (red)

Displays the fuel level in the fuel tank. When only the last bar is displayed (low fuel), this last bar, and “E” and “Low Fuel” symbols turn red, and the other bars are gray. When the fuel is above the last bar, all bars and the “E” and “Low Fuel” symbols are white.

21. Speedometer

Displays current vehicle speed. You can toggle the speedometer between km/h (kilometers per hour) and mph (miles per hour).

22. Coolant temperature gauge

Both excessively low and excessively high coolant temperatures are harmful. Idle the engine to warm it up when it’s too cold, stop the vehicle if the engine is too hot to prevent overheating. Always keep the coolant temperature within the safe range.

7. CONTROLS AND FUNCTIONS

MAIN SWITCH

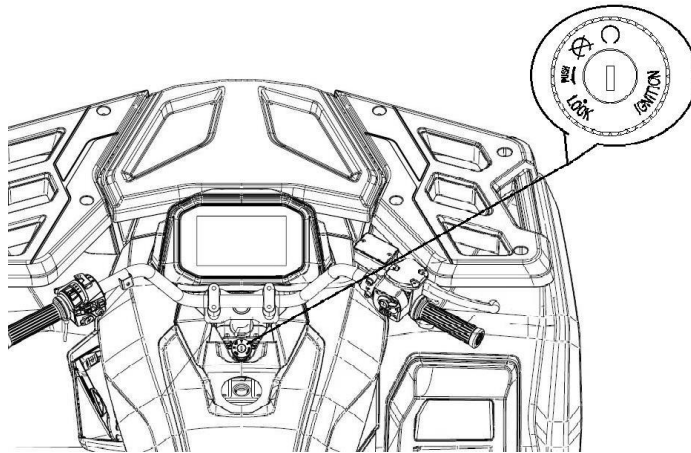

WARNING

Do not attach large items to your ignition key, such as bulky keychains or key fobs. They may come into contact with the handlebars during turns, potentially interfere with the electrical system and could cause the engine to shut off unexpectedly while riding. This could result in serious injury or death.

The Main Ignition Switch has three positions:

⊙: All electrical circuits are on. Engine can be started. Key cannot be removed in this position.

⊗: All electrical circuits are switched off. The key can be removed in this position.

“LOCK”: The steering is locked in this position to help prevent vehicle theft. Key can be removed in this position.

NOTE:

Your ATV was supplied with a set of two keys - a primary and a spare key. Remove the spare key and keep it in a safe place, separately from the vehicle. New key can only be made from blank key using an original key. If both keys are lost, the entire Main Switch assembly must be replaced.

7. CONTROLS AND FUNCTIONS

2WD / 4WD Drive Mode Switch

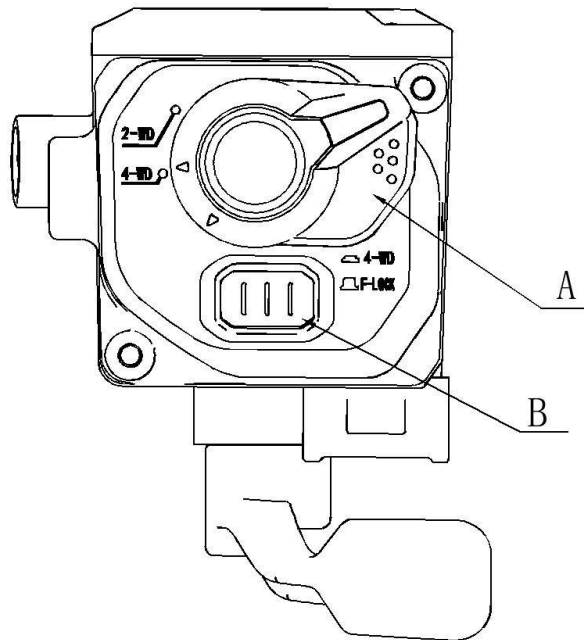

This vehicle is equipped with drive mode switch, allowing you to select 2WD, 4WD, or F-LOCK/4-WD drive modes. Use this switch to select the drive mode that best suits required traction, and terrain conditions.

- A: Selects two-wheel drive (2WD) or four-wheel drive (4WD) mode.
- B: Switches between four-wheel drive (4WD) and four-wheel drive lock (F-LOCK).



WARNING

Always stop the vehicle completely before switching drive modes!
Changing modes while the vehicle is still in motion can result in severe damage to the drivetrain components.

7. CONTROLS AND FUNCTIONS

“F-Lock” Drive Mode

In “F-Lock” mode, both front wheels are locked together and rotate at the same speed to provide maximum front wheel traction. The steering will require more force for turning. The drive mode indicator on the dashboard will flash until front differential lock is engaged. Do not ride until the differential lock is fully engaged (when the indicator light is still flashing). Riding before the differential lock is completely engaged will cause the engine speed to be limited until differential lock is fully engaged. Maximum speed in F-lock mode is limited to 30 km/h. If conditions require full engine power to be available, press the Override switch on the left handlebar switch to temporarily disable the speed limiting function.

Throttle Lever

Once the engine is running, operating the throttle lever by your thumb increases or decreases engine speed. Control the vehicle’s speed using the throttle.

The throttle lever is spring-loaded: when you release it, the engine will automatically return to idle and the machine will slow down.

Before starting the engine, check that the throttle lever operates smoothly and returns to the idle position immediately after releasing.

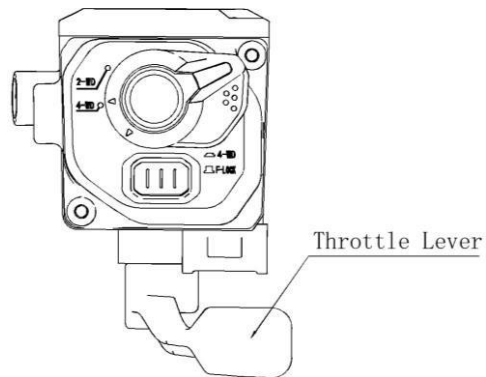

WARNING

Operating an ATV with sticking or improperly operating throttle could cause an accident.

Never start or operate an ATV that has a sticking or improperly operating throttle. Immediately contact your dealer for service if throttle problems arise.

Failure to check or maintain proper operation of the throttle can result in an accident if the throttle lever sticks during ride. Always check the throttle lever for free movement and easy return before starting the engine. Also check occasionally during ride.

7. CONTROLS AND FUNCTIONS

USB Port and 12V Power Socket (IF EQUIPPED)

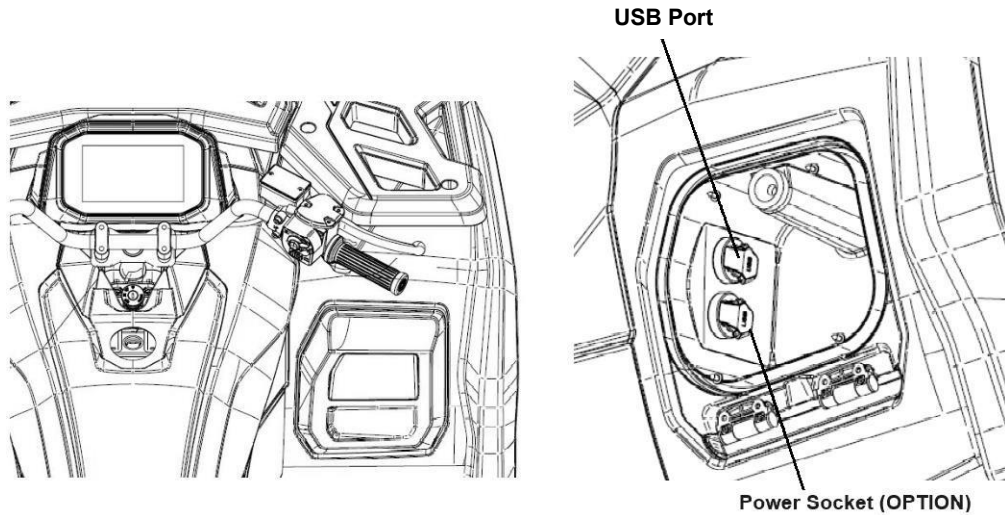

USB port and 12V power socket (if equipped) are located on the right front fender. They can be used to power electrical accessories such as handheld spotlights, or to charge electronic devices. Consult your dealer regarding the use of powered accessories with your vehicle.

Hand and Foot Brake

The hand and foot brakes should be checked before each ride. The front brake lever is located on the right handlebar and the foot brake pedal is located on the right floorboard.

CAUTION

Once a bottle of brake fluid is opened, use what is necessary and discard the rest. Do not store or use a partial bottle of brake fluid. Brake fluid is hygroscopic, meaning it rapidly absorbs moisture from the air. This causes the boiling temperature of the brake fluid to drop, which can lead to early brake fade and the possibility of severe injury.

7. CONTROLS AND FUNCTIONS

Front Brake

Front brake lever is located on the right handlebar. Front brake is hydraulically activated disc brake, and brakes front wheels only.

Always test brake lever movement and brake fluid level in reservoir before riding. When squeezed, brake lever should feel firm. Any sponginess indicates a possible brake fluid leak, or low brake fluid level in master cylinder reservoir, which must be corrected before riding. Contact your dealer for advice, diagnosis or repair.



WARNING

Use caution when applying the front brake. Do not aggressively apply the front brake, the front wheels may lock up and the ATV will lose steering or tip over.

Foot Brake

The foot brake pedal is located on the right side floor board of the vehicle. Pushing down on the pedal applies the front and rear brakes at the same time. The rear brake is hydraulically activated disc type brakes. Always test brake pedal travel and reservoir fluid level before riding. When squeezed, the pedal should feel firm. Any sponginess would indicate a possible fluid leak or low master cylinder fluid level which must be corrected before riding. Contact your dealer for proper diagnosis and repairs.



WARNING

Never operate the ATV with a spongy brake lever feeling. Operating the ATV with a spongy brake lever can result in loss of braking. Loss of braking could cause an accident.

7. CONTROLS AND FUNCTIONS



WARNING

Never operate the ATV with unbalanced front brakes. Operating the ATV with unbalance front brakes can result in loss of control and cause an accident. If the ATV pulls to one side during braking, have the brakes inspected by Linhai authorized service as soon as possible.

Setting the Parking Brake

The parking brake brakes the rear wheels.



Parking brake lock

1. Firmly grasp the left hand brake and engage the parking brake lock.
2. To release the parking brake lock, firmly grasp the left hand brake. The lock will return to its released position.

Important safeguards

- The parking brake may relax when left on for a long period time. This could cause an accident.
- Do not leave the vehicle on a hill relying on the parking brake for more than five minutes.

7. CONTROLS AND FUNCTIONS

- Always block the downhill side of the wheels if leaving the ATV on a hill or park the ATV in a side hill position.

Always check to be sure that the parking brake has been disengaged before operating the ATV. An accident could result causing severe injury if the parking brake is left on while the ATV is operated.

Brake Fluid Level

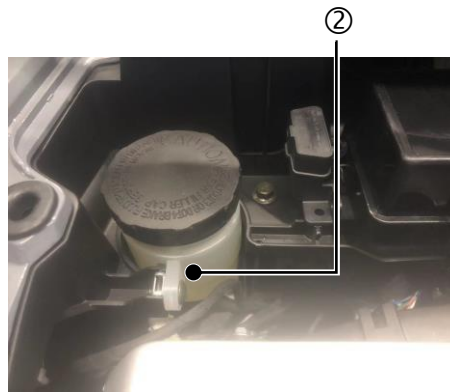
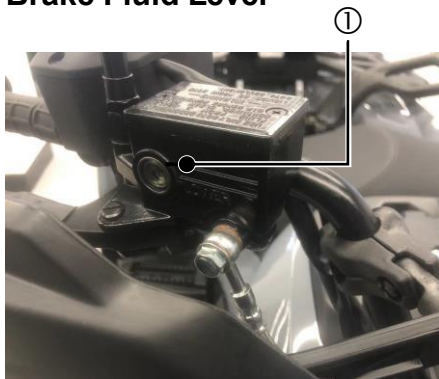

Front brake

The front brake master cylinder is located on the handlebars. Check the brake fluid level in reservoir before each ride. There is an control window ① on the master cylinder, the fluid level can be seen through it. Brake fluid level should be maintained between the “MAX” and “MIN” marks on the reservoir.

Rear brake

Remove the front access cover and check the foot brake fluid level. When checking the brake fluid level, the ATV must be on level ground. If fluid level is lower than the "Min" mark ②, add DOT 4 brake fluid.

Do not overfill.

7. CONTROLS AND FUNCTIONS

Seat

Seat installation:

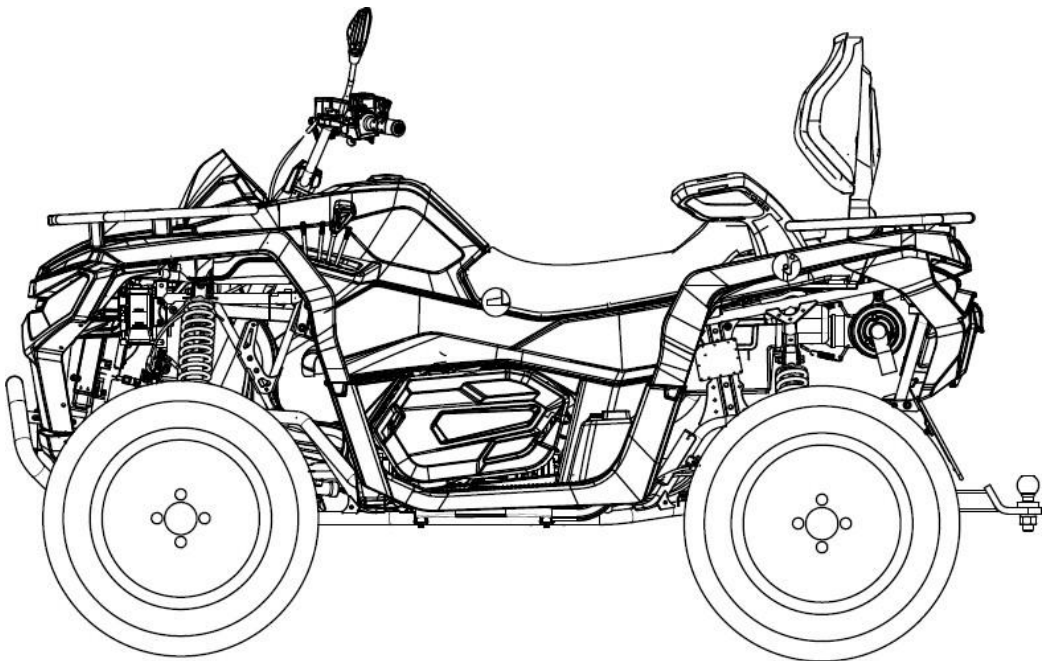
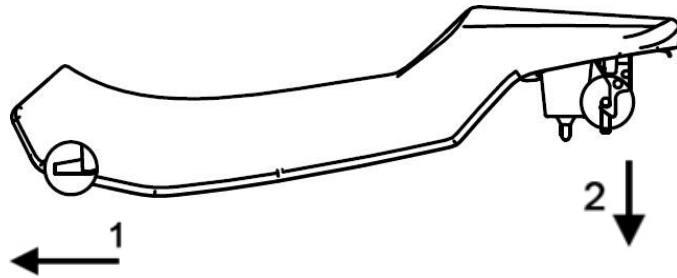

To avoid personal injury:
Make sure the seat is properly locked in place.

7. CONTROLS AND FUNCTIONS

GEAR SELECTOR



The gear selector is located on the left side of the vehicle. The selector lever has four positions:

- Low gear
- High gear
- Neutral
- Reverse

L - Low gear. The low speed range. It allows the vehicle to move slowly with maximum torque at the wheels. Use Low gear when riding on steep slopes, pulling loads, or navigating rough terrain.

NOTE:

To avoid damage to the CVT system, always use Low gear during continuous low-speed operation, when pulling a trailer, carrying heavy cargo, climbing over obstacles, or driving on hills.

H - High gear. High speed range of the gearbox. This is the normal driving speed range. It allows the vehicle to reach its maximum speed.

N - Neutral. In neutral, the engine power is not transmitted.

R - Reverse. The reverse gear allows the vehicle to go backwards. Speed is limited in reverse to 30 km/h.



CAUTION

To change gears, completely stop the vehicle, and with the engine in idle, move the lever to the desired gear. Shifting gears with the engine speed above idle or while the vehicle is moving could cause transmission damage.

Whenever the ATV is left unattended, always lock the parking brake.

7. CONTROLS AND FUNCTIONS

FUEL TANK

Fuel tank cap is located at the front of the rider. Open the fuel tank cap ① by turning it counterclockwise.

Recommended fuel:

95 Octane Unleaded Gasoline E10 (with max. 10% ethanol)

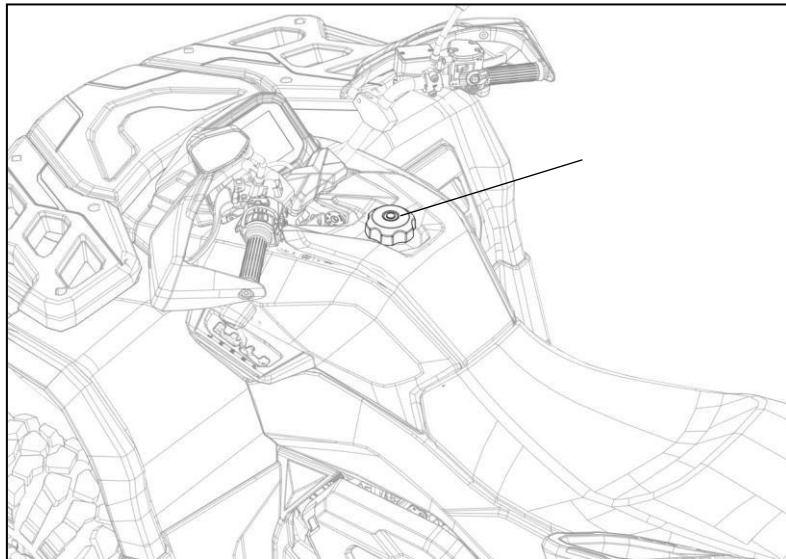

7. CONTROLS AND FUNCTIONS

FUEL AND OIL SYSTEM

Fuel safety



WARNING

Gasoline is highly flammable and explosive under certain conditions.

- Always exercise extreme caution whenever handling gasoline.
 - Always refuel with the engine stopped and outdoors, or in a well ventilated area.
 - Do not smoke or allow open flames or sparks in or near the area where refueling is performed or where gasoline is stored.
 - Do not overfill the tank. Do not fill to the tank neck.
 - If you get gasoline on your skin or clothing, immediately wash it off with soap and water, and change clothing.
 - Never start the engine or let it run in an enclosed area. Gasoline engines exhaust fumes are poisonous and can cause loss of consciousness and death in a short time.
-



WARNING

The engine exhaust from this product contains chemicals known, in certain quantities, to cause cancer, birth defects or other reproductive harm.

Recommended Fuel: Unleaded Gasoline, 95 Octane (E10)

Fuel tank capacity: 22L



CAUTION

Use only unleaded gasoline. The use of leaded gasoline will cause severe damage to internal engine parts, such as the valves and piston rings, as well as to the exhaust system. Use only 95 octane or higher gasoline.

7. CONTROLS AND FUNCTIONS

Engine Oil

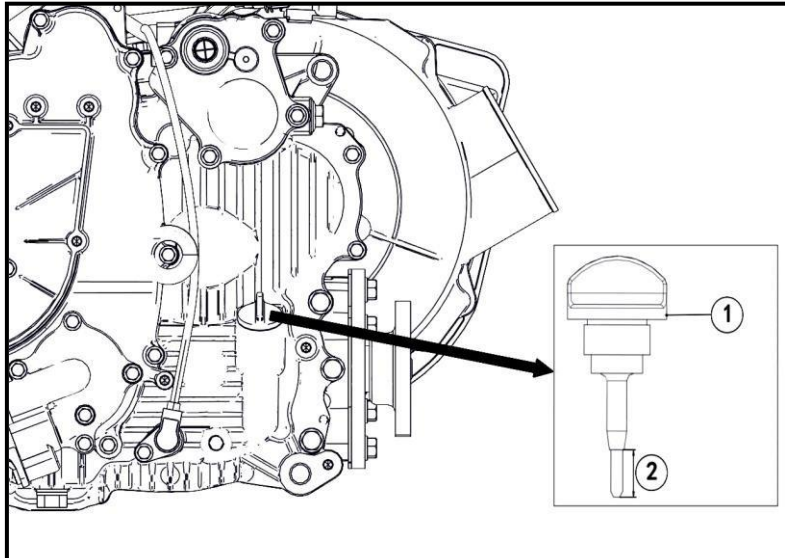

① Oil dipstick ② Recommended range

The oil tank / oil dipstick is located on the left side of the engine.

To check the oil:

1. Place the machine on a level surface
2. Start the engine and let it idle for 20-30 seconds.
3. Stop the engine, remove oil dipstick ① and wipe it dry with a clean cloth.
4. Put dipstick into the oil tank (don't screw it in), remove it and read the oil level.
5. Remove the dipstick and check if the oil level is within the recommended range ②. Add oil as indicated by the level on the dipstick. Do not overfill.



CAUTION

Use only SAE 10W/50, SF oil. Never substitute or mix oil brands. Serious engine damage and voiding of warranty can result.

7. CONTROLS AND FUNCTIONS

Cooling System

Coolant Level

The recovery bottle, located under the seat, must be maintained between the minimum and maximum levels indicated on the recovery bottle.

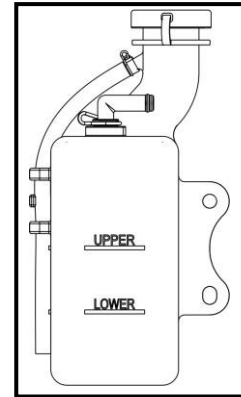

The engine coolant level is controlled or maintained by the recovery system. The recovery system components are the recovery bottle, radiator filler neck, radiator pressure cap and connecting hose.

As coolant operating temperature increases, the expanding (heated) excess coolant is forced out of the radiator past the pressure cap and into the recovery bottle. As engine coolant temperature decreases, the contracting (cooled) coolant is drawn back up from the tank past the pressure cap and into the radiator.

NOTE: Some coolant level drop on new machines is normal as the system is purging itself of trapped air. Observe coolant level and maintain as recommended by adding coolant to the recovery bottle. Linhai recommends the use of a high quality aluminum compatible anti-freeze coolant.

NOTE: Always follow the manufacturer's mixing recommendations for the freeze protection required in your area.

Cooling System



WARNING

Never remove the pressure cap when the engine is warm or hot. Escaping steam can cause severe burns. The engine must be cool before removing the pressure cap.

Radiator Coolant Level Inspection

NOTE: This procedure is only required if the cooling system has been drained for maintenance and/or repair. However, if the recovery bottle has run dry, the level in the radiator should be inspected and coolant added if necessary.

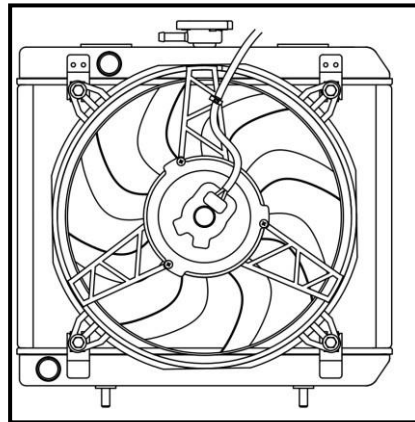

NOTE: Use of a non-standard pressure cap will not allow the recovery system to function properly. If the cap should need replacement contact your dealer for the correct replacement part. To insure that the coolant maintains its ability to protect the engine, it is recommended that the system be completely drained every two years and a fresh mixture of antifreeze and water be added.

Using a funnel, slowly add coolant as necessary through the radiator filler neck.

7. CONTROLS AND FUNCTIONS

Starting a Cold Engine



WARNING

Never run an engine in an enclosed area. Carbon monoxide in exhaust gases is poisonous and can cause severe injury or death. Always start engine outdoors, or in well ventilated area.



WARNING

POTENTIAL HAZARD

Freezing of control cables in cold weather.

WHAT CAN HAPPEN

You could be unable to control the vehicle, which could lead to an accident or collision.

HOW TO AVOID THE HAZARD

When riding in cold weather, always make sure all control cables work smoothly before you begin riding.

1. Verify the gear selector is shifted to the Neutral position.

NOTE: When the drive select lever is in the neutral position, the Gear Position Indicator display “N”. If the Gear Position Indicator does not display “N”, ask a dealer to inspect the electric circuit.

It is recommended to shift into Neutral before starting the engine.

2. Apply the foot brake or hand brake.

3. Turn the engine stop switch and main switch to “” (ON).

4. Keep your thumb off the throttle lever, then push the start button “” on the left handlebar switches.

NOTE: Do not press the throttle lever while starting the engine.

5. Once the engine starts, let the engine warm up for a short period before riding.

NOTE: If the engine does not start, return the key to the OFF position “” and wait 5 seconds before attempting to start again. Activate the starter button for another 5 seconds if necessary. Repeat this procedure until the engine starts.



CAUTION

Operating the vehicle immediately after starting, with cold engine, could cause engine damage. Allow the engine to warm up for several minutes before operating the vehicle.

If the engine does not start immediately, do not press the starter button continuously. Repeated failed attempts to start the engine may damage the starter motor.

10. RIDING GEAR

The break-in period for your new ATV are the first 20 hours of operation. No single action on your part is as important as a proper break-in. Careful treatment of new engine will result in more efficient performance and longer life for the engine. Carefully follow these steps:

1. Fill the fuel tank.
2. Check engine oil level on the dipstick. Add oil if necessary.
3. Drive slowly at first. Select an open area that provides enough space to familiarize yourself with the vehicle's operation and handling.
4. Do not operate at sustained idle.
5. Perform regular checks on fluid levels, controls and all important areas on the vehicle as outlined on the daily pre-ride inspection checklist – see "4. Pre-ride inspection".
6. Don't pull any loads in break-in period.
7. Break-in engine oil and filter - change at 20 hours or 320 km.



CAUTION

To avoid engine damage during the break-in period:

- Do not load or tow cargo.
- During the first 20 hours of use, avoid running the engine at sustained full throttle to prevent engine damage and extend engine life.
- For the first 10 hours (or 160 km), do not open the throttle more than 1/2 of the throttle travel.
- Between 10 and 20 hours of use (or between 160 km and 320 km), do not open the throttle more than 3/4 of the throttle travel.

9. VEHICLE BREAK-IN PERIOD

SAFE RIDING GEAR

Always wear proper clothing for your riding style. ATV riding requires special protective clothing which will make you feel more comfortable and reduce chances of injury.

1. Helmet

Your helmet is the most important piece of protective gear for safe riding. A helmet can prevent a severe head injury.

Wear an approved off-road motorcycle helmet that fits properly.

2. Eye Protection

Pair of goggles or helmet with face shield offer the best protection for your eyes.

3. Gloves (off-road style)

Wear off-road gloves for comfort and protection against the sun, cold weather, and other elements.

4. Boots

Wear sturdy over-the-ankle off-road boots suitable for the terrain you will be riding in.

5. Clothing

To protect your body, long sleeves and pants should always be worn. Layering system and durable reinforced materials provide the best protection against abrasions, nicks, cuts, and weather.

11. CARRYING LOADS



POTENTIAL HAZARD

Operating this vehicle without wearing an approved motorcycle helmet, eye protection, and protective clothing.

WHAT CAN HAPPEN

Operating without an approved motorcycle helmet increases your chances of a severe head injury or death in the event of an accident.

Operating without eye protection can result in an accident and increases your chances of a severe injury in the event of an accident.

HOW TO AVOID THE HAZARD

Always wear an approved motorcycle helmet that fits properly. You should also wear eye protection (goggles or face shield), gloves, boots, long pants and long-sleeved shirt or jacket.

10. RIDING GEAR

CARRYING LOADS

Cargo weight can change the stability and handling of a vehicle.

Use common sense and good judgment when carrying cargo. Keep the following points in mind:

- Never exceed the weight limits. An overloaded vehicle can be unstable.
- Make sure the load does not interfere with controls or your ability to see where you are going.
- Drive more slowly than you would without a load. The more weight you carry, the slower you should go.
- Allow more braking distance. A heavier vehicle takes longer to stop.
- Avoid making sharp turns unless at very slow speeds.
- Avoid hills and rough terrain. Choose terrain carefully. Added weight affects the stability and handling of the vehicle.

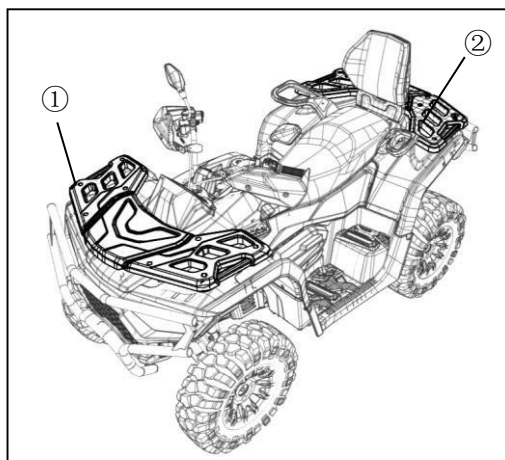

① 1/3 of cargo weight front

② 2/3 of cargo weight rear

12. DRIVING YOUR VEHICLE



WARNING

POTENTIAL HAZARD

Overloading the vehicle.

WHAT CAN HAPPEN

Could cause changes in vehicle handling which could lead to an accident.

HOW TO AVOID THE HAZARD

Never exceed the stated load capacity for this vehicle. Cargo should be properly distributed and securely attached. Reduce speed when carrying cargo. Allow greater distance for braking.



WARNING

POTENTIAL HAZARD

Carrying a passenger on the cargo rack.

WHAT CAN HAPPEN

The passenger could fall or be struck by objects on the cargo rack.

HOW TO AVOID THE HAZARD

Never carry a passenger on the cargo rack. The cargo rack is designed to carry cargo only.

11. CARRYING LOADS



WARNING

Gear Selector positions

This ATV has four gear positions: Low, High, Neutral, Reverse, see picture:

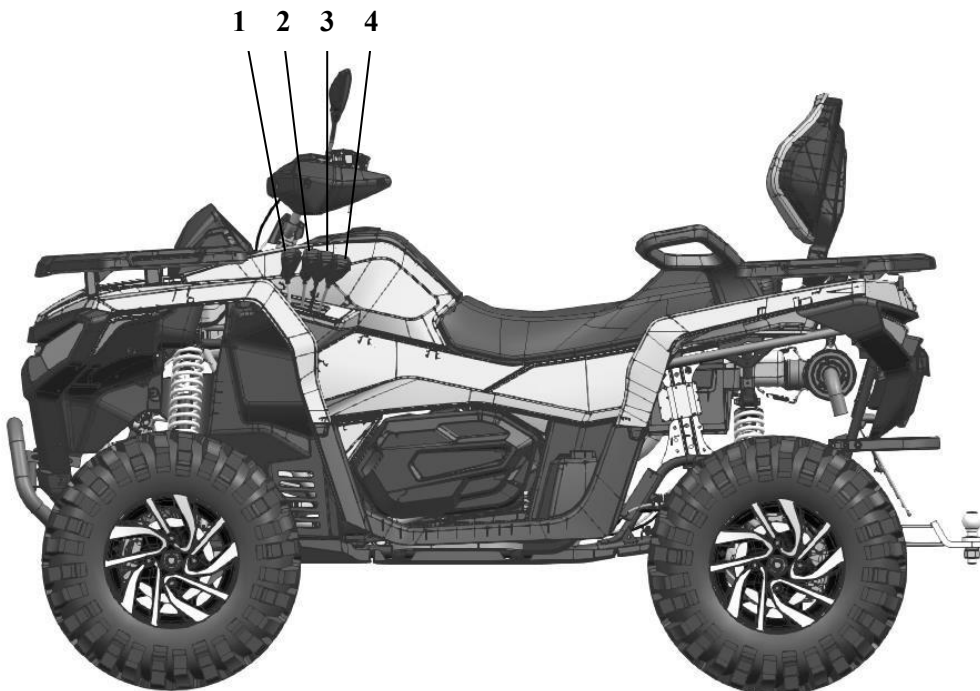

1. Low speed
2. High speed
3. Neutral
4. Reverse

12. DRIVING YOUR VEHICLE



WARNING

You must inspect your ATV each time before riding to ensure it is in proper working order. If proper inspection is not done, severe injury or death could result. See **“4. PRE-RIDE INSPECTION”**

LEARNING TO OPERATE YOUR VEHICLE

You should become familiar with the performance characteristics of your ATV in a large, flat area free of obstacles and other vehicles. Practice control of the throttle, brakes, steering, and gear selector lever. Drive at slow speed at first and become comfortable at that speed before gradually increasing your speed. Become familiar with the way the vehicle feels in low and high ranges, first in two-wheel drive (2WD), then in four-wheel drive (4WD). Also practice driving in reverse. Take time to learn basic operation before attempting more difficult maneuvers.

1. Set the parking brake, shift to neutral, and start the engine, allowing it to warm up.
2. With the engine idling, shift the gear select lever into "L" or "H" position. Then release the parking brake.
3. Press the throttle with your right thumb slowly and smoothly. The automatic centrifugal clutch will engage and you will start to accelerate. Avoid higher speeds until you are thoroughly familiar with the operation of your vehicle in slow speed.

12. DRIVING YOUR VEHICLE

4. When slowing down or stopping, release the throttle lever and smoothly press the brake pedal. Bear in mind that improper use of the brakes can cause the tires to lose traction, reducing control and increasing the possibility of an accident.

Making turns

To make a turn, steer in the direction of the turn, leaning your upper body to the inside of the turn while supporting your weight on the outer footrest. This technique alters the balance of traction between the wheels, allowing turn to be made smoothly. The same leaning technique should be used for turning in reverse.

Practice making turns at slow speeds before attempting to turn at faster speeds.



WARNING

Turning at sharp angles or at excessive speeds can result in vehicle overturn and lead to serious injury.

Avoid turning at sharp angles.

Never make turns at high speeds.

12. DRIVING YOUR VEHICLE

Traction and Turning in 2WD / 4WD / 4WD/F-LOCK modes

To achieve maximum traction while operating in 2WD or 4WD, the two rear wheels perform as one axle and turn together at the same speed. Furthermore, when operating in 4WD/F-LOCK mode, the front wheels are also locked together and turn at the same speed. Therefore, unless the inside wheel is allowed to slip or lose some traction, greater force will be required to turn the ATV.

Cornering Technique

As you approach a curve, slow down and begin turning the handlebars in the desired direction. As you do so, put your weight on the footboard to the outside of the turn (opposite the desired direction) and lean your upper body into the turn. Use the throttle to maintain a steady speed through the turn. This maneuver will let the wheels on the inside of the turn slip slightly, helping the ATV to turn properly.

12. DRIVING YOUR VEHICLE

Riding on slippery surfaces

Whenever riding on slippery surface such as mud or loose gravel, or during cold freezing weather, special attention must be paid to prevent vehicle from overturning.

Always:

1. Slow down when entering slippery areas.
2. Maintain a high level of alertness, reading the trail and avoiding quick, sharp turns which can cause skids.
3. Correct a skid by turning the handlebars in the direction of the skid and shifting your body weight forward.
4. Never brake during a skid. Complete loss of ATV control can result.
5. Do not operate on excessively slippery surfaces.
6. Always reduce speed and exercise extra caution.



WARNING

Failure to exercise caution when operating the ATV on slippery surfaces can be dangerous.

Loss of tire traction and vehicle control can result in an accident, including an overturn.

12. DRIVING YOUR VEHICLE

Going Uphill



WARNING

Exercise extreme caution when going uphill.

Braking and handling are greatly affected. Loss of vehicle control or overturning of the ATV could occur, causing severe injury or death.

Whenever traveling uphill, always go straight up the hill.

1. Avoid steep hills (18% maximum).
2. Keep both feet on the footrests.
3. Shift your weight forward.
4. Proceed at a steady speed and throttle opening.
5. Remain alert and be prepared to take emergency action. This may also include quick dismounting of the ATV.

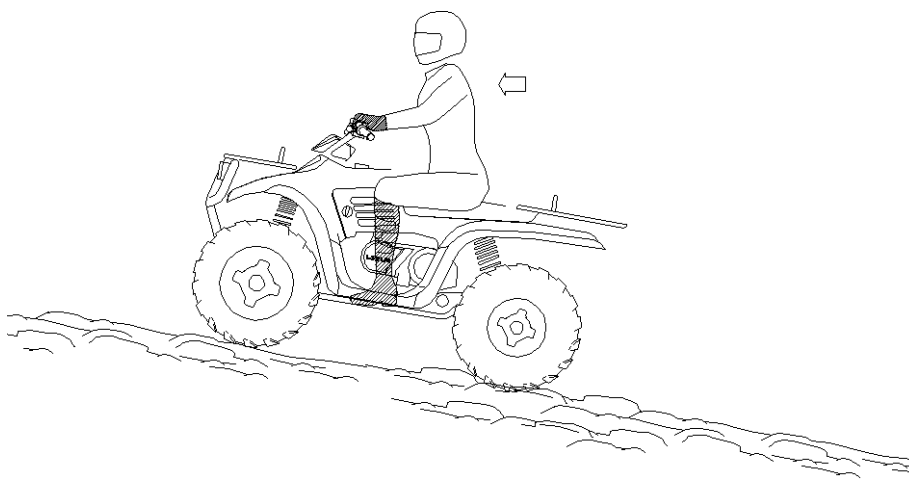

12. DRIVING YOUR VEHICLE

Side hilling (Traversing a slope)

Side hilling your ATV is one of the most dangerous types of riding and should be avoided. If you are in a situation where side hilling is necessary:

1. Slow down.
2. Lean into the hill transferring your upper body weight toward the hill while keeping your feet on the footrests.
3. Steer slightly uphill to maintain the intended direction.

If vehicle begins to tip, quickly turn the front wheel down the hill, if possible, or dismount the ATV on the uphill side immediately!



WARNING

Improperly crossing hills or turning on hills can be dangerous. Loss of vehicle control or overturning of the ATV could occur, causing severe injury or death.

12. DRIVING YOUR VEHICLE

Going Downhill

Whenever descending a hill, always:

1. Drive directly downhill.
2. Transfer your weight to the rear of the ATV.
3. Slow down.
4. Apply the brakes slightly to aid in slowing.



WARNING

Do not go down the hill at excessive speed. It is dangerous and can cause loss of vehicle control and tipping over, resulting in severe injury or death.

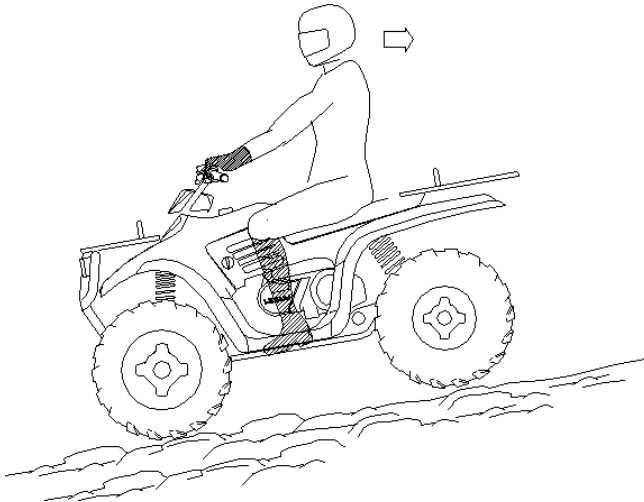

12. DRIVING YOUR VEHICLE

Turning Around On A Hill (K-Turn)

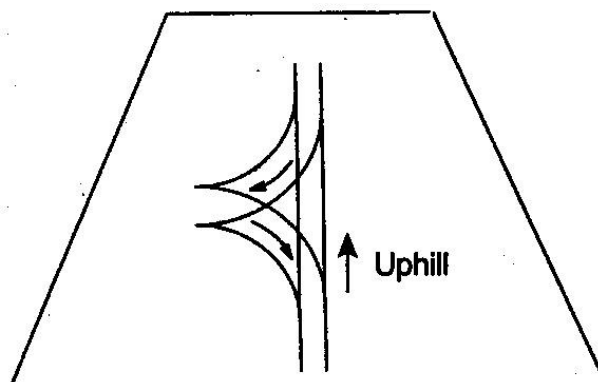

If the ATV stalls while climbing a hill, never back it down the hill! One maneuver which can be used when it is necessary to turn around while climbing a hill, is the “K-turn”.

1. Stop and lock the parking brake while maintaining body weight uphill.
2. Shut off the engine.
3. Dismount on left or uphill side of ATV.
4. Staying uphill of the ATV, turn handlebars full left (while facing front of ATV).
5. While holding the brakes, release the parking brake and slowly allow the ATV to roll to your right until it points across the hill or slightly downhill.
6. Lock the parking brake and remount the ATV from the uphill side, maintaining your body weight uphill.
7. Restart engine, release parking brake, and proceed slowly, controlling speed with the foot brake, until ATV is on reasonably level ground.

Avoid climbing steep hills. Loss of vehicle control or overturning of the ATV could occur resulting in severe injury or death.

12. DRIVING YOUR VEHICLE

Water Crossing

This ATV can operate through water up to a maximum depth of 315 mm. Before crossing the streams, always:

1. Determine water depth and current.
2. Choose a crossing where both banks have gradual inclines.
3. Proceed slowly, avoiding rocks and obstacles if possible.
4. After leaving the water, dry the brakes by applying light pressure to the brake lever until normal braking performance is restored.

CAUTION

Never operate the ATV through deep or fast flowing water.

NOTE: After operating in water, it is critical your machine is serviced according to the Maintenance chart, see chapter “16. Maintenance”. The following areas need special attention: engine oil, transmission oil, air filter, CVT system, and all grease fittings.

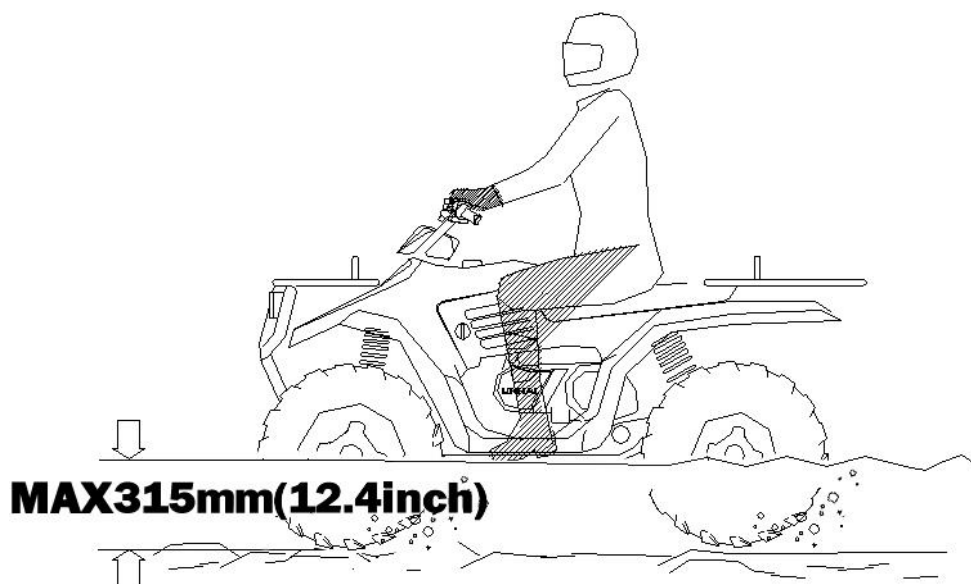

12. DRIVING YOUR VEHICLE

CAUTION

If your ATV becomes immersed, do not start the engine. Take it to your dealer for a thorough inspection to prevent major engine damage.

If it is impossible to take your machine to dealer without starting the engine, follow these steps:

- Move the ATV to dry ground or at the very least, to water no deeper than 315 mm.
- Inspect and service the air filter after water immersion.
- Remove the spark plug.
- Crank the engine several times with the electric starter.
- Dry the spark plug and reinstall or replace it with a new plug.
- Try to start the engine. If necessary, repeat the procedure.
- Take the machine to your dealer for service as soon as possible whether you succeed in starting, or not.

If water has been ingested into the CVT system, take the ATV to your dealer for service as soon as possible.

12. DRIVING YOUR VEHICLE

Trail Safety

Keep Alert!

Look ahead and learn to read the trail as you ride. Stay on the right side of the trail, if possible, and be constantly alert for hazards such as logs, rocks, low hanging branches and other trail users or vehicles.

Not all obstacles are visible. Travel with caution on trails. Severe injury or death can occur if a vehicle comes in contact with a hidden obstacle.

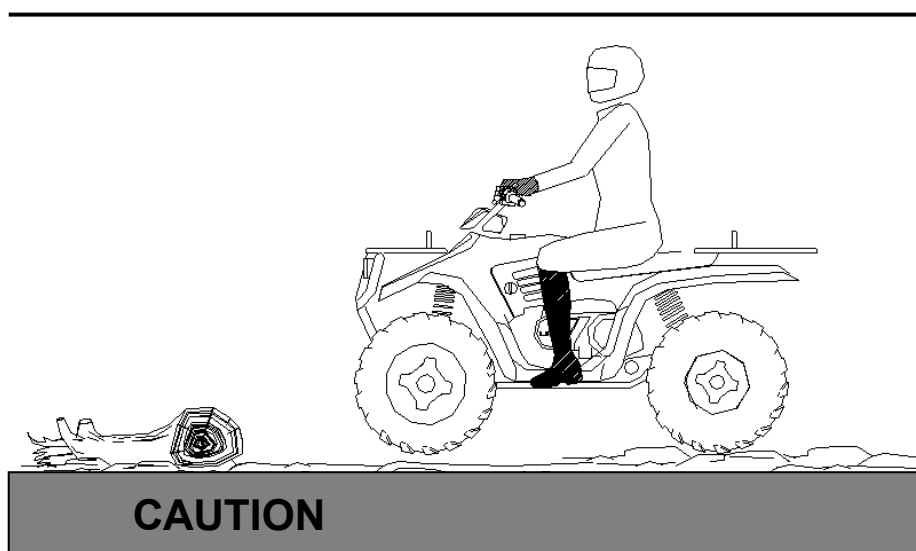

Opening the throttle more than necessary can cause excess fuel to accumulate in the exhaust, leading to engine popping and/or engine damage.

Parking On An Incline

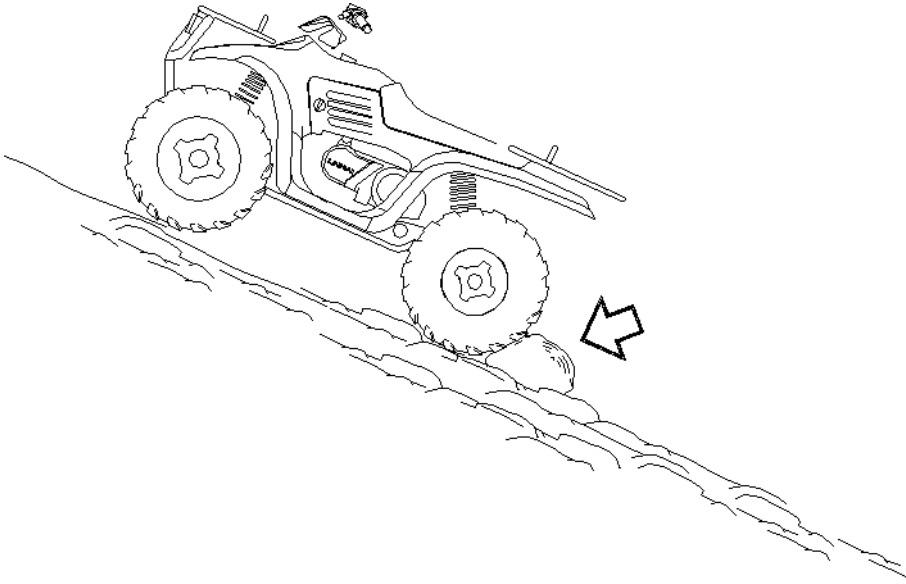

Whenever the vehicle is parked:

1. Turn the engine off.
2. Place the gear selector to N position and use parking brake
3. Always block the rear wheels on the downhill side as shown.
4. Avoid parking on an incline, if possible. If parking on an incline is necessary, always block the rear wheels on the down hill side as shown in the picture.
5. Do not leave the ATV parked on a hill relying solely on the parking brake for more than five minutes.

13. CVT SYSTEM



WARNING

The CVT system rotates at high speeds, creating large amount of force on clutch components. As the owner you have the following responsibilities to make sure this system remains safe:

- Do not modify any component of the CVT system. Doing so may reduce its strength so that a failure may occur at high speeds. Any modification will cause the system to be out of balance, creating vibration and additional loads on components.
 - Routine maintenance is the responsibility of the owner. Always follow recommended maintenance procedures, or visit your dealer.
 - The CVT cover must be securely in place during operation. Failure to comply with this warning can result in severe injury or death.
-

Low Range Use May Reduce CVT Operating Temperatures

The basic operation of the CVT system depends on engine speed and the vehicle's torque demands. As engine speed increases, the centrifugal force from the flyweights pushes the movable drive sheave closer, tightening the drive belt. Similarly, when engine speed decreases, this force is reduced, and the drive belt is engaged less tightly. When operating in Low Range, the engine runs at higher RPM for a given speed but with decreased forces applied to the CVT belt and drive sheaves. This often results in reduced heat generation in the CVT system and can help keep CVT temperatures lower by optimizing belt grip and reducing slippage.

On ATV, the gear ratio difference between High and Low Range is about 1:1.88. This difference affects how the CVT operates, especially at speeds below 11 km/h. Using Low Range for low speeds can help keep CVT temperatures lower by maintaining better belt tension and reducing slippage.

Reducing the temperature inside the clutch cover extends the life of the CVT components (belt, cover, etc.).

13. CVT SYSTEM

When To Use Low Range

The following guidelines describe situations when you should use Low Range rather than High Range.

Low Range

- Operation at speeds less than 11 km/h.
- Heavy pulling
- Riding through rough terrain (swamps, hills, etc.) at low speeds

High Range:

- Normal driving range at speeds greater than 11 km/h.
- High speeds

This vehicle is equipped with low maintenance battery (MF), which is located under the seat. It is not necessary to check the electrolyte or add distilled water into the battery.



WARNING

Do not try to remove the sealing caps on the battery cells. You may damage the battery.



WARNING

Always ensure the battery cable connections have the correct polarity when reinstalling the battery. When removing the battery, always disconnect the RED (positive) cable last. When installing, reconnect the RED (positive) cable first.



DANGER

Maintenance-Free batteries contain sulfuric acid, which is corrosive and can cause serious injury. Avoid contact with skin, eyes, or clothing. Always wear eye protection when working near batteries. Keep out of reach of children.

Antidote:

External: Flush with water.

Internal: Drink large quantities of water or milk. Follow with milk of magnesia, beaten egg, or vegetable oil. Call physician immediately.

Eyes: Flush with water for 15 minutes and get prompt medical attention.

Batteries produce explosive gases. Keep sparks, flame, cigarettes, etc. away. Ventilate when charging or using in an enclosed space.

14. BATTERY

BATTERY REMOVAL

Turn off the engine and all electrical systems before removing the battery.

1. Remove the passenger and operator seats.
2. Remove the frame protection plate.
3. Remove the battery strap.
4. Disconnect the BLACK (negative) cable first.
5. Disconnect the RED (positive) cable next.
6. Lift the battery out of the ATV carefully.

BATTERY INSTALLATION

Using a new battery that has not been fully charged can damage the battery and result in a shorter life. It can also hinder vehicle performance. Follow the battery charging instructions in the Battery Charging section before installing the battery.



CAUTION

Your ATV is equipped with a 20 Ah battery (or 30 Ah battery for EPS model). This may not be sufficient to provide power for optional equipment. When installing optional equipment please upgrade your battery as necessary. Consult your dealer for battery recommendation.



WARNING

To avoid the possibility of explosion, always connect Red (positive) cable first; black (negative) cable last. An exploding battery can cause serious injury or death.

14. BATTERY



WARNING

Battery terminals and connections should be kept free of corrosion. Corroded terminals mean poor electrical contact, starting issues, and reduced battery performance. Clean the battery terminals regularly with a soft wire brush and then apply dedicated contact cleaner, such as the Maxima Electrical Contact / Brake Cleaner. Finally, coat the terminals and terminal bolts with electrical contact grease.

1. Place the battery in its holder.
2. Connect and tighten the red (positive) cable first.
3. Then connect and tighten the black (negative) cable.
4. Make sure the cables are properly routed and secured.
5. Reinstall the battery strap.
6. Reattach the frame protection plate.
7. Reinstall the operator and passenger seats.

BATTERY STORAGE

NOTE:

- If the vehicle will not be used for one month or longer, remove the battery and store it in a cool, dry place. Completely recharge the battery before reinstallation.
- A special battery charger is required for recharging low maintenance batteries. Using a conventional battery charger may shorten the battery life. We suggest using the Shark CT-4000 automatic charger for maintaining and charging this 12V MF battery.
- When installing a new battery, make certain it is always fully charged prior to its use. Using a new battery that has not been fully charged can damage the battery resulting in a shorter life of the battery. It can also hinder vehicle performance.

BATTERY CHARGING

- The following battery charging instructions apply only to charging the sealed (MF) battery. Read all instructions before proceeding with the installation of this battery.
- The sealed battery is already filled with electrolyte and has been sealed at the factory. Never pry the sealing strip off, or add any fluid to this battery.
- The single most important thing about maintaining a sealed MF battery is to keep it fully charged. Use fully automatic smart 8-stage Shark CT-4000 battery charger for maintaining and charging your 12V MF battery.



WARNING

An overheated battery may explode, causing severe injury or death. Using incompatible or low-quality chargers can increase this risk. If the battery becomes very warm during charging, stop charging immediately and allow it to cool. Do not resume charging until the cause of overheating has been identified and resolved.

14. BATTERY

15. EXHAUST SYSTEM

EXHAUST SYSTEM REGULATION

TAMPERING WITH NOISE CONTROL SYSTEM IS PROHIBITED!

CAUTION:

Exhaust system components are very hot during and after ride!

- Do not touch exhaust system components. Serious burns can result.
- Be especially careful when riding through dry, tall grass. The potential for fire exists.

SPARK ARRESTOR

The spark arrestor in the exhaust pipe must be periodically cleaned to remove accumulated carbon deposits as follows:

1. Remove the 3 bolts and the spark arrestor ① from the end of the muffler.
2. Use a non-synthetic brush to clean the spark arrestor screen. A synthetic brush may melt if components are hot. If necessary, blow the spark arrestor screen with compressed air.
3. Inspect the screen for wear and damage. Replace the arrestor, if damage is found.
4. Reinstall the arrestor.

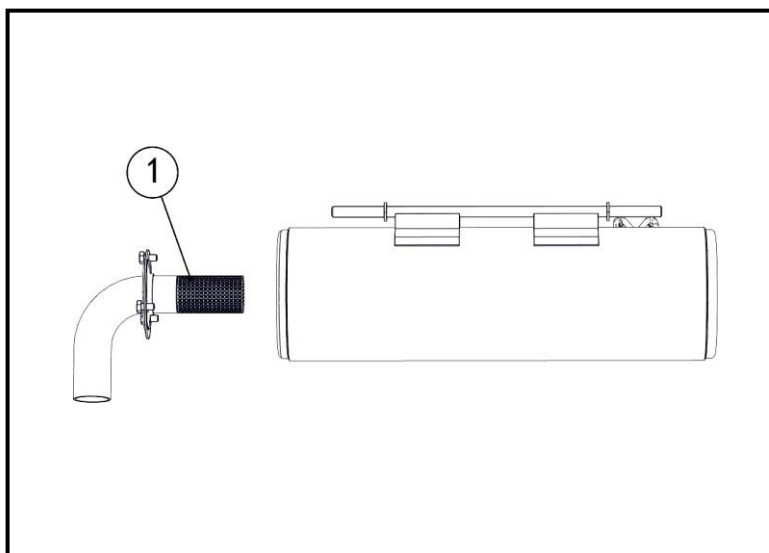

15. EXHAUST SYSTEM



WARNING

Failure to observe the following warnings while servicing the spark arrestor could result in serious injury or death.

- Do not perform service on the spark arrestor while the system is hot. Allow components to cool sufficiently before proceeding.
- Wear eye protection and gloves.
- Never operate the vehicle without the spark arrestor.
- Never run the engine in an enclosed area. Exhaust gases contain poisonous carbon monoxide.



WARNING

The engine RPM limiter activates at 7400 rpm. Running the engine above this limit may cause excess fuel to accumulate in the exhaust system, which can be ignited by the catalytic converter in the muffler, **POTENTIALLY LEADING TO MUFFLER OVERHEATING AND FIRE RISK**. Always reduce throttle when the engine approaches maximum RPM to avoid engine popping.



WARNING

The engine exhaust from this product contains chemicals known, in certain quantities, to cause cancer, birth defects or other reproductive harm.

16. MAINTENANCE

PERIODIC MAINTENANCE

Linhai authorized dealer can perform any service, replace, repair or check that may be necessary for your vehicle. We also recommend using LINHAI genuine parts for service and regular maintenance.

Tampering with or removing emission control components is prohibited under EU law and may invalidate type-approval compliance of the vehicle.

Owners are responsible for performing the scheduled maintenance described in this owner's manual.

Careful periodic maintenance will help keep your vehicle in the safest, most reliable condition. Inspection, adjustment and lubrication of important components are explained in this manual.

Inspect, clean, lubricate, adjust and replace parts as necessary. When inspection reveals the need for replacement parts, Linhai genuine parts are available from your dealer.

Service and adjustments are important for proper vehicle operation. If you're not familiar with service and adjustment procedures, Linhai authorized dealer can perform these operations.

Vehicles subjected to heavy or severe use must be inspected and serviced more frequently.

SEVERE USE DEFINITION:

- Frequent immersion in mud, water or sand
- Frequent or prolonged operation in dusty environments
- Short trips in cold weather operation
- Racing or sport-style operation at high RPMs
- Prolonged low speed or heavy load operation
- Extended idle

In cold weather, pay special attention to the engine oil level. An increase in oil level during cold conditions may indicate contamination in the oil sump or crankcase. If the oil level starts to rise, change the oil immediately. Continue to monitor the oil level, and if it keeps rising, stop using the vehicle and identify the cause before using the vehicle again. Your dealer can assist.

16. MAINTENANCE



WARNING

Vehicles subjected to heavy or severe use should be serviced according to the maintenance interval charts below – see items marked "XU".

SYMBOL	DESCRIPTION
XU	Perform these procedures more often for vehicles subjected to severe use.
D	Have an authorized dealer perform these services.



WARNING

Improperly performing procedures marked with a "D" could result in component failure and lead to serious injury or death. Have an authorized dealer perform these services.

MAINTENANCE INTERVALS

NOTE:

The maintenance interval chart outlines required maintenance and inspection based on engine hours / calendar time / mileage. Each table states the number of hours / calendar/ miles that service is required on the vehicle. Some items or components may need to be serviced more often due to severe use, such as operation in water, or under severe loads. These items are marked with "XU".

Pre-Ride Check

ITEM	REMARKS
D Steering system	Visually inspect, test, or check components. Make adjustments and/ or schedule repairs when required.
D Throttle return	
Front suspension and axles	
Rear suspension and axles	
Tires	
Brake fluid level	
Brake lever / foot brake function	
Brake system function	
Wheels / fasteners	
Engine oil level	

16. MAINTENANCE

XU	Air filter / Air box and connections	Visually inspect. Replace filter when dirty.
D	Headlight aim / General lighting and turn indicators	Inspect. Adjust or replace lights when necessary.
XU	Radiator	Inspect for mud or debris blocking airflow. Clean surfaces if necessary.

AFTER BREAK-IN SERVICE - 20 HOURS / 320 KM

ITEM	REMARKS	
	General lubrication	Lubricate all grease points, pivots, cables, etc.
	Engine oil / oil filter	Change oil and oil filter.
XU	Air filter	Inspect. Replace if dirty. Do not clean
D	Valve clearance	Check and adjust as necessary.
	Front / Rear gear case oil	Check level. Inspect for leaks.
	Coolant	Check level. Inspect for leaks.
XU	Brake pads	Inspect pad thickness.
	Battery	Check terminals, clean, test battery condition if required.
D	Idle	Inspect for proper rpm. Ask dealer for service if out of spec or erratic.
D	Steering / Wheel Alignment	Inspect steering system. Ask dealer for service if wheel alignment is required.
XU	Foot brake / Hand brake	Inspect function. Adjust as necessary.
	Gearcases, CV shafts, Prop shafts	Inspect for leaks.
	Engine hoses, gaskets and seals	Inspect for leaks.

16. MAINTENANCE

50 HOURS / 6 MONTH / 800 KM SERVICE

ITEM		REMARKS
XU	Air filter	Always inspect pre-ride. Inspect frequently if subjected to severe use. Replace if dirty. Do not clean.
XU	General lubrication	Lubricate all fittings, pivots, cables, etc.
	Cooling system	Test coolant strength. Pressure test system yearly.
XU	Radiator	Inspect. clean external surfaces. Clean more frequently if subjected to severe use.
D	Steering system	Inspect. Lubricate.
XU	Front suspension	Lubricate. Check fasteners.
XU	Rear suspension	Lubricate. Check fasteners.
XU	Gear shift mechanism	Inspect, lubricate, adjust as necessary.
XU D	Throttle body / throttle cable	Inspect. Clean. Lubricate.

100 HOURS / 12 MONTH / 1600 KM SERVICE

ITEM		REMARKS
XU	Front gear case oil	Inspect level. Change yearly if hours or distance interval is not met.
XU	Rear gear case oil	Inspect level. Change yearly if hours or distance interval is not met.
XU	Engine oil / oil filter	Change yearly if hours or distance interval is not met.
XU D	CVT drive belt	Inspect. Replace as necessary. Ask dealer for service.
D	CVT drive and driven pulleys	Clean and Inspect pulleys. Replace worn parts. Ask dealer for service.
	Fuel filter and hoses	Inspect routing and condition. Replace filter and high-pressure hoses every 4 years.
	Cooling hoses	Inspect routing and condition.
XU	Valve clearance	Inspect and adjust as necessary. Ask dealer for service.
D	Fuel system	Inspect fuel tank, cap, fuel pump and fuel pump relay

16. MAINTENANCE

	Spark plug	Inspect. Replace if worn or fouled.
D	Engine mounts	Inspect condition.
	Exhaust pipe and spark arrestor	Inspect. Clean spark arrestor.
XU	Wiring, fuses, connectors, relays, and cables	Inspect wire routing for wear, security. Apply dielectric grease as necessary to connectors subjected to water, mud etc.
XU D	Wheel bearings	Inspect for noise or looseness Replace as necessary.
	Idle	Inspect for proper rpm. Ask dealer for service if out of spec or erratic.
D	Steering / Wheel Alignment	Inspect steering system. Ask dealer for service whenever steering parts or wheel alignment are required.
XU	Foot brake height	Inspect. Replace brake pads or adjust height as required.

200 HOURS /24 MONTH/ 3200 KM SERVICE

ITEM		REMARKS
	Coolant	Change coolant every 2 years if hours or distance interval is not met.
XU	Brake fluid	Inspect fluid for color change. Change fluid every two years.

16. MAINTENANCE

LUBRICATION RECOMMENDATIONS

Check and lubricate all components at the intervals outlined in the Periodic Maintenance Chart, or more often under severe use such as in wet or dusty conditions. Items not listed in the chart should be lubricated at the general lubrication intervals.

ITEM	LUBE
Engine Oil	MAXIMA ATV PREMIUM 10W40
Brake Fluid	MAXIMA DOT 4 Brake Fluid
Front gear case oil	MAXIMA PREMIUM GEAR OIL 80W90
Rear gear case oil	MAXIMA PREMIUM GEAR OIL 80W90
Suspension pivots and drivetrain moving parts (joints and grease fittings)	MAXIMA Waterproof Grease

16. MAINTENANCE

The following items should be checked occasionally for tightness, or if they have been loosened for maintenance service.

WHEEL NUT TORQUE SPECIFICATIONS

Bolt Size	Tightening torque
Front M10 x 1.25	41 Nm
Rear M10 x 1.25	41 Nm

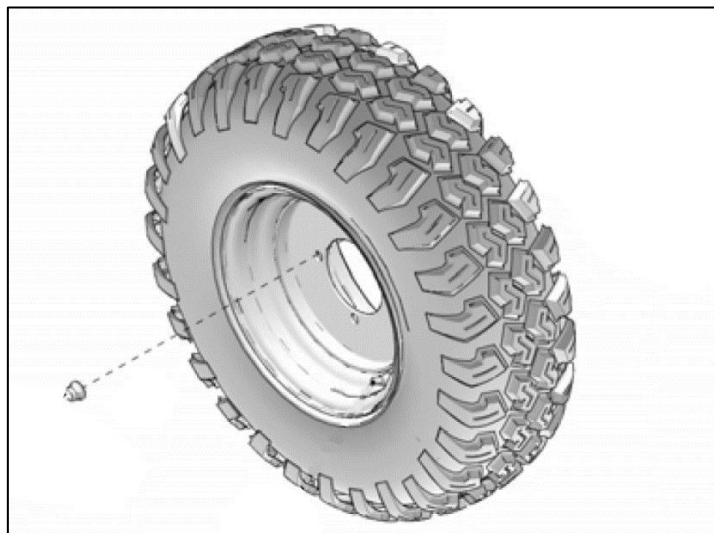

Wheel Hub Tightening

Wheel bearing tightness and spindle nut retention are critical component operations. Service work must be performed by an authorized dealer.

16. MAINTENANCE

WARNING

Improper adjustment of the handlebars or incorrect torque of the adjuster block tightening bolts can cause limited steering or loosening of the handlebars, resulting in loss of control and possible serious personal injury or death.

Handlebars adjustment Your ATV has handlebars which can be adjusted for your personal fit.

1. Remove the handlebar cover.
2. Loosen the four bolts.
3. Adjust handlebar to desired position. Be sure handlebars do not hit fuel tank or any other part



- of the machine when turned fully to left or right.
4. Tighten the handlebar adjuster block bolts to 14-16 Nm.

NOTE: Tighten the handlebar clamp bolts so that the gaps at the front and rear of the handlebar block are equal. Uneven gaps may result in the handlebars not being tightened securely, which can compromise safety.

16. MAINTENANCE

AIR FILTER SERVICE

Inspect the air filter at the intervals specified in the Periodic Maintenance Chart. In extremely dusty conditions, air filter replacement will be required more often. Access the air box near the right rear wheel.

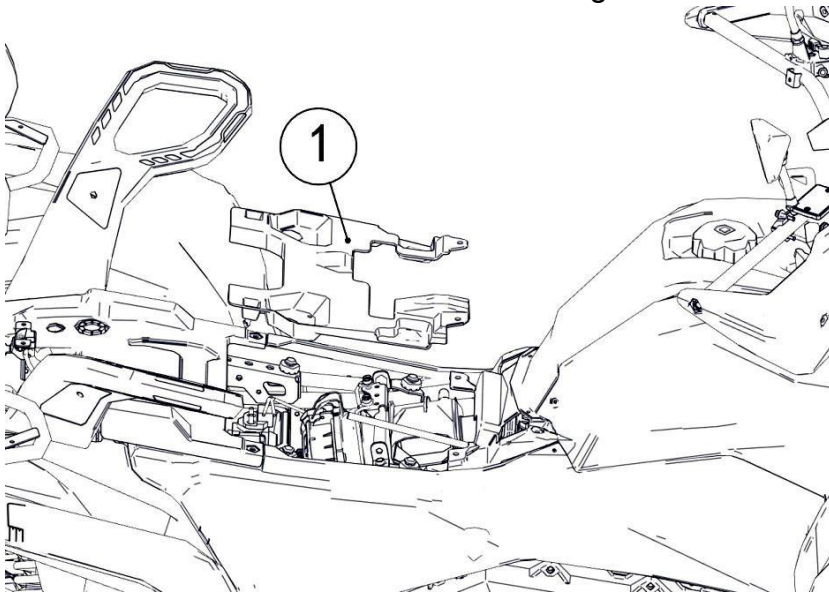

① Frame protection plate

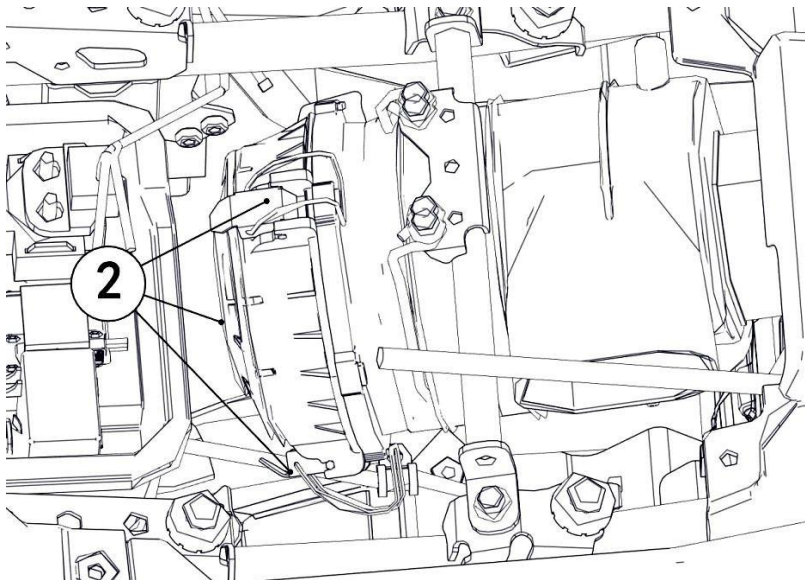

② Cover latches (x3)

16. MAINTENANCE

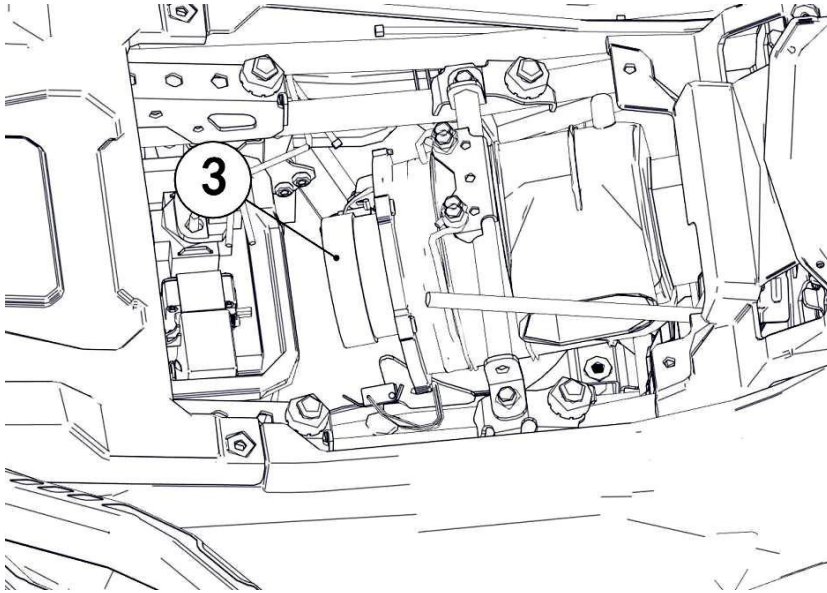

③ Air filter

1. Remove frame protection plate ①.
2. Release the three cover latches ②.
3. Unlatch the cover and carefully remove it from the air box.
4. Remove the air filter ③.
5. Inspect the air box for oil or water deposits. Wipe away any deposits with a clean shop towel.

Note: If the filter has been soaked with fuel or oil, it must be replaced.

6. Inspect the air filter and replace it if necessary.

Note: DO NOT attempt to clean the air filter with compressed air.

7. Place the air filter into the air box and reinstall the air box cover.

Note: Make sure the tabs are properly positioned into the hinge. Ensure the O-ring is installed inside the lid properly.

8. Engage the cover latches.

16. MAINTENANCE

BRAKE SYSTEM

WARNING

Once a bottle of brake fluid is opened, use what is necessary and discard the rest. Do not store or use a partial bottle of brake fluid. Brake fluid is hygroscopic, meaning it rapidly absorbs moisture from the air. This causes the boiling temperature of the brake fluid to drop, which can lead to early brake fade and the possibility of serious injury.

Front brake

The front brake is hydraulic disc brake, operated by depressing the brake lever on the right handlebar. These brakes are self-adjusting and require no adjustment. The following checks are recommended to keep the brake system in good operating condition. How often they need checking depends upon the type of driving that has been done.

- Keep correct fluid level in the master cylinder reservoir. Normal functioning of the diaphragm is to extend into the reservoir as fluid level drops. If the fluid level is low, and the diaphragm is not extended, a leak is indicated and the diaphragm should be replaced. Always fill the reservoir as indicated whenever the cover is loosened or removed to insure proper diaphragm operation. Use DOT 4 brake fluid.
- Check brake system for leaks.
- Check brake for excessive travel or spongy feel.
- Check friction pads for wear, damage and looseness.
- Check security and surface condition of the discs.
- Pads should be changed when friction material is worn to 1 mm (A).

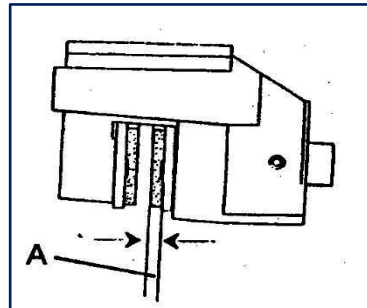

Foot Brake

- The foot brake is a hydraulic disc type brake which is activated by the foot pedal. This brake is self adjusting and requires no maintenance other than periodic checks of the pads for wear.
- Pads should be changed when the friction material is worn to 1mm.
- Inspect the brake disc and pad wear surface for excessive wear.

16. MAINTENANCE

Checking the brake fluid level

Insufficient brake fluid may let air enter the brake system, possibly causing the brakes to become ineffective. Before riding, check that the brake fluid is above the minimum level mark and replenish if necessary. A low brake fluid level may indicate worn brake pads and/or brake system leakage. If the brake fluid level is low, be sure to check the brake pads for wear, and the brake system for leakage.



Front brake:

Check brake fluid level in the master cylinder, located on the handlebars.

Rear brake (foot brake):

Remove the front service cover and check the foot brake fluid level.

- When checking the fluid level, make sure the top of the brake fluid reservoir is level.
- Use only the recommended brake fluid. Otherwise, the rubber seals may deteriorate, causing leakage and poor braking performance.
- Refill with the same type of brake fluid. Mixing fluids may result in a harmful chemical reaction, resulting in poor braking performance.
- Be careful not to allow water to enter the brake fluid reservoir when refilling. Water will significantly lower the boiling point of the brake fluid and may result in vapor lock.
- Brake fluid may deteriorate painted surfaces or plastic parts. Always clean up spilled fluid immediately.
- Have an authorized dealer inspect the brake system if the brake fluid level goes down.

Throttle Free Play Check:

1. Apply the parking brake.
2. Shift the transmission to neutral.
3. Start the engine and warm it up thoroughly.
4. Start to slowly open the throttle and measure the throttle lever movement before the engine RPM starts to increase. The free play should be 1.5 - 3 mm.

16. MAINTENANCE

SPARK PLUG

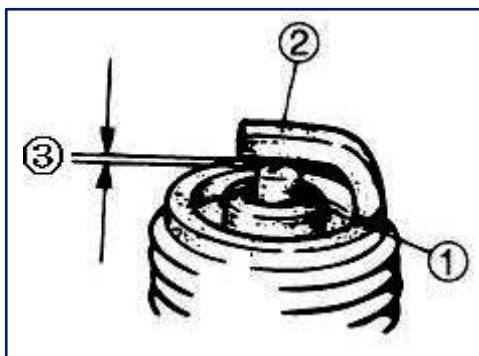

③ Gap: 0.8-0.9 mm

Standard spark plug:
NGK DPR8EA-9

Inspect:

- Insulator ①
Abnormal color: Replace.
Normal color is a medium-to-light tan color.
- Electrode ②
Wear/damage: Replace. Clean.
- Spark plug
(clean with wire brush)

Measure:

- Spark plug gap ③
Out of specification: adjust gap.

Spark Plug Removal and Replacement



WARNING

Never attempt to remove a spark plug while the engine is warm.
The exhaust system or engine could burn you, causing severe injury.

1. Remove the spark plug by turning it counterclockwise.
2. Reverse the procedure for spark plug installation. Torque the spark plug to **23 Nm**.

16. MAINTENANCE

ENGINE OIL

ENGINE OIL CHECK

Note:

Maintain the oil level within the safe range on the dipstick. Do not overfill.

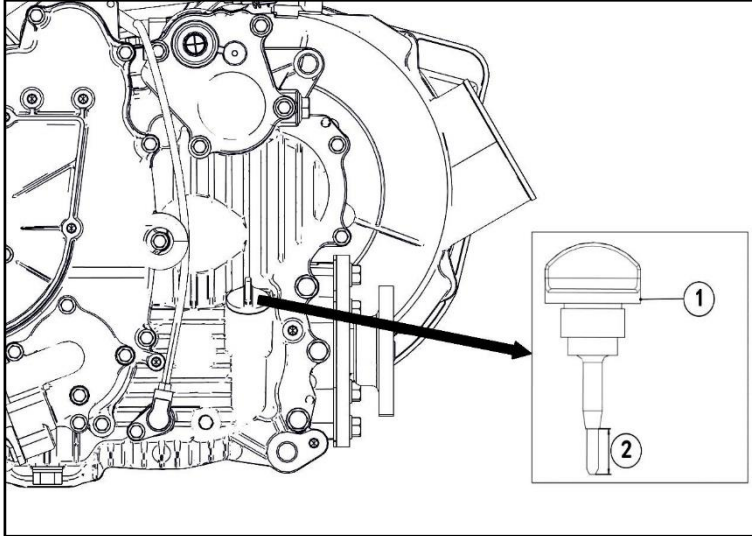

1. Position the vehicle on a level surface.
2. Remove the dipstick ①. Wipe it dry with a clean cloth.
3. Put dipstick back into the oil tank (don't screw it in).
4. Remove the dipstick and check if oil level is within safe range ②.
5. Add the recommended oil as needed.
6. Reinstall the dipstick.



CAUTION

Too much or too little oil will have an impact on the normal operation of the engine. Make sure the oil is maintained between the upper and lower marks of the dipstick.

ENGINE OIL AND FILTER CHANGE

Have the engine oil and oil filter changed at an authorized service center at the intervals specified in the maintenance chart.

16. MAINTENANCE

FRONT AND REAR GEARCASE OIL LUBRICATION

Because of the unique design, where draining and filling the gearcase is required to produce the correct oil level, please visit authorized Linhai service to check or change oil level / maintain / replace gear oil in front and rear gearcases at the intervals specified in the Maintenance chart.

16. MAINTENANCE

WHEELS AND TIRES

WARNING

Operating your ATV with worn or improperly inflated tires, non-standard or improperly installed tires will affect vehicle handling which could cause an accident resulting in serious injury or death.

Follow the safeguards listed below to prevent this type of situation.

Important Safeguards

Maintain proper tire pressure according to charts below. Improper tire inflation may affect ATV maneuverability.

Do not use improper tires. The use of non-standard size or type tires may affect ATV handling.

Make sure the wheels are installed properly. If wheels are improperly installed, it could affect vehicle handling and tire wear.

Tire Pressure	
Front	Rear
48 kPa (0,48 bar)	48 kPa (0,48 bar)

Wheel Removal

1. Stop the engine, place the transmission in gear and lock the parking brake.
2. Loosen the wheel nuts slightly.
3. Elevate the side of the vehicle by placing a suitable stand under the footrest frame.
4. Remove the wheel nuts and remove the wheel.

Wheel Installation

1. With the transmission in gear and the parking brake locked, place the wheel in the correct position on the wheel hub. Be sure the valve stem is toward the outside and rotation arrows on the tire point toward forward rotation.
2. Attach the wheel nuts and finger tighten them.
3. Lower the vehicle to the ground.
4. Securely tighten the wheel nuts according to the chart in “**16. MAINTENANCE/ Wheel Nuts Torque**”.

16. MAINTENANCE

Tire Inspection

When replacing a tire, always use the size and type specified in the Specifications section of this manual and in your vehicle registration documents.

Tire Tread Depth

Always replace tires when the tread depth is worn down to 3 mm or less. Worn tires reduce traction and control, increasing the risk of slipping or losing stability, which can compromise your safety while riding.

For optimal performance and safety, always replace tires in pairs or as a complete set.

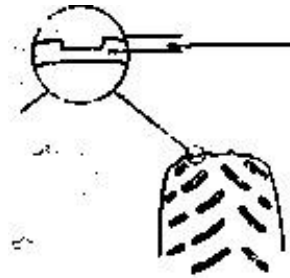

16. MAINTENANCE

LIGHTING



WARNING

Keep your headlights and taillights clean at all times. Reduced visibility from dirty lights increases the risk of accidents, which may cause serious injury or death.

LED Headlights Replacement

LED headlight unit is a sealed and cannot be serviced. If the LED light is damaged or fails, have the entire LED headlight assembly replaced by Linhai authorized dealer.

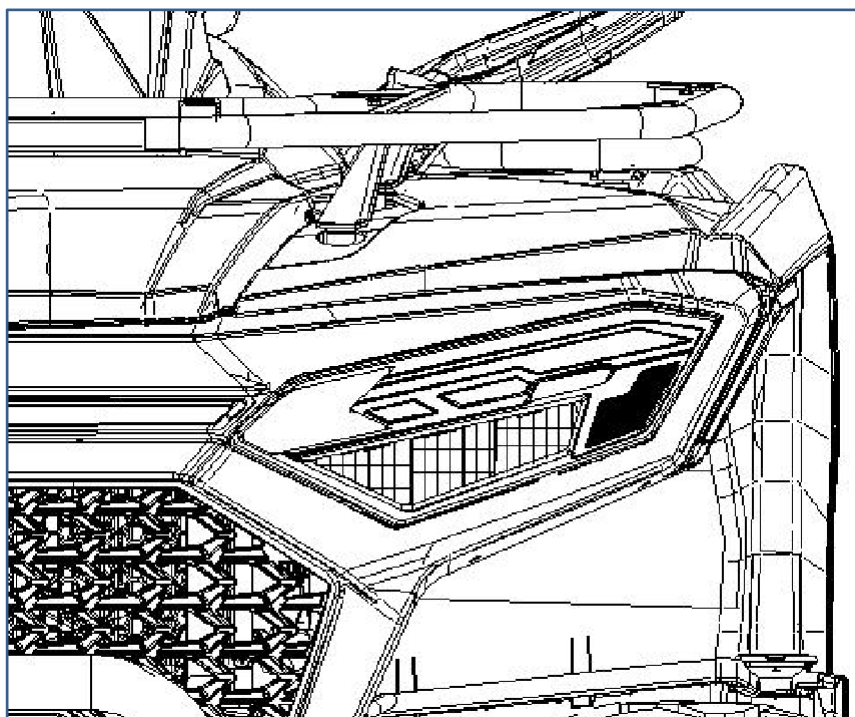

16. MAINTENANCE

Headlight Beam Adjustment



WARNING

It is advisable to have your dealer make this adjustment. Turn the adjusting screws to raise or lower the beam.

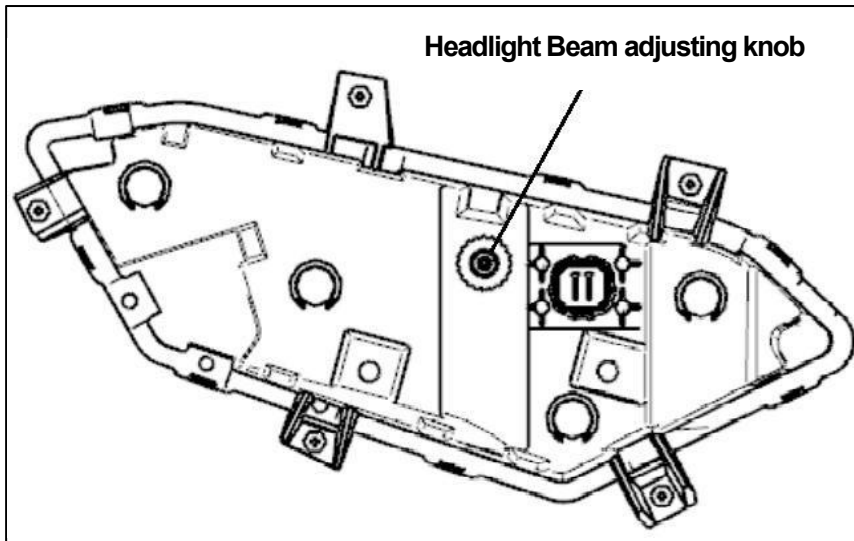

1. To lower the headlight beam, turn the adjustment knob counterclockwise. To raise the beam, turn the knob clockwise.
2. This vehicle is equipped with LED headlights that are non-serviceable. If a headlight becomes damaged or fails, contact Linhai authorized dealer for replacement.

Tail/Brake Light Replacement

The tail and brake light assemblies are non-serviceable LED units. If a light becomes damaged or fails, the entire assembly must be replaced. Please contact Linhai authorized dealer for service.

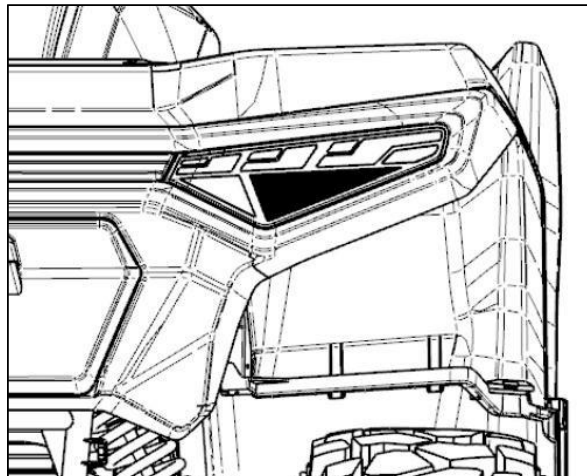

16. MAINTENANCE

CLEANING YOUR ATV

Keeping your ATV clean will extend life of the components.

Washing your ATV

Never use high pressure car washers. Water can damage wheel bearings, transmission seals, body panels, brakes, warning labels; water might enter the engine, TFT display or exhaust system.

The best and safest way to clean your ATV is with a garden hose and a mild soap with water. Use a professional washing products, cleaning the upper body first and lower parts last. Rinse with water frequently and dry with a chamois to prevent water spots.

NOTE: If warning labels are damaged, contact your dealer for new ones.

Waxing

Your ATV can be waxed with any non-abrasive automotive wax. Avoid using harsh or abrasive products, as they may damage the body finish.

CAUTION

Certain products, including insect repellents and other chemicals, will damage plastic surfaces. Care must be taken when using these products on plastic surfaces.

STORAGE

CAUTION

Do not start the engine during the storage period. This will disturb the protective film created by fogging.

Cleaning—Clean the ATV thoroughly.

Fuel—Its best to drain the fuel tank for long-term storage. However, when starting the ATV again, ensure that there is enough fuel in the fuel tank (The fuel gauge indicator is more than one segment).

Oil and Oil Filter Change—Warm the engine and change the oil and oil filter.

Air Filter/Air Box—Inspect and clean / replace the air filter. Clean the air box and drain the sediment tube.

Inspect All Fluid Levels—Inspect the following fluid levels and change if necessary: transmission; brake fluid (change every two years or as required if fluid looks dark or contaminated).

16. MAINTENANCE

Fog the Engine—Spray a light oil into the cylinder through the spark plug hole.

Check and Lubricate Cables/Grease—Inspect all cables and lubricate them.

Battery Maintenance—Remove the battery and store it in a dry place. Apply Dielectric Grease to the terminal bolts and terminals. Charge the battery every month.

Storage Area / Covers—Check tire pressure and safely support the ATV with the tires 2,5-5 cm off the ground. Be sure the storage area is well ventilated. Cover the machine with a ATV cover.

NOTE: Do not use plastic or coated ATV covers. They do not allow enough ventilation to prevent condensation, and may promote corrosion and oxidation.

TRANSPORTING YOUR ATV

Whenever the ATV is to be transported, following measures should be taken:

1. Turn the engine off and remove the key.
2. Check that the fuel cap, oil cap, and seat are installed correctly.
3. Tie the frame of the ATV to the transporting vehicle securely using suitable straps.
4. Place the transmission in gear and lock the parking brake.

17. TROUBLESHOOTING

This section provides guidance to help you identify common issues that may affect vehicle operation. Diagnosing more complex problems may require the expertise of a qualified technician. If a solution is not obvious, contact Linhai authorized dealer.

Improper Use - CVT Clutch and Drive Belt Burning

Possible Causes	Solutions
Insufficient engine warm-up in low ambient temperatures.	Warm up the engine for at least 5 minutes with the transmission in neutral. Gently apply throttle in short bursts (about 1/8 throttle) 5 to 7 times to make the belt more flexible and prevent belt burning.
Slow and easy clutch engagement.	Fast, effective use of the throttle for efficient engagement.
Stuck in mud or snow.	Carefully use fast, brief, aggressive throttle application to engage clutch. WARNING: Excessive throttle may cause loss of control and vehicle overturn.
Climbing over large objects from a stopped position.	Carefully use fast, brief, aggressive throttle application to engage clutch. WARNING: Excessive throttle may cause loss of control and vehicle overturn.

Low Battery

Possible Cause	Solutions
Starting a faulty engine for an extended period.	See Section 8, "Starting the Engine," and inspect the fuel / air / ignition / and compression systems.
Leaving the main switch (key) on while parking the ATV.	When stopping the engine, turn off the main switch (key) off immediately.



WARNING

This ATV is equipped with EFI system, If the battery is under 12.6 Volt, the engine will not start.

17. TROUBLESHOOTING

NOTE:

The following trouble shooting does not cover all the possible causes of trouble. It should be helpful, however, as a guide to troubleshooting. Refer to the relative procedure in this manual for inspection, adjustment and replacement of parts. Adjustment and replacement must be done by your dealer.

STARTING FAILURE / HARD STARTING	
FUEL SYSTEM	
Fuel tank	
<ul style="list-style-type: none"> • Empty • Clogged fuel tank breather pipe • Deteriorated fuel or fuel containing water or foreign material • fuel filter clogging • the fuel pressure not correct 	<ul style="list-style-type: none"> • Fill fuel tank • Clean or replace breather pipe • Replace deteriorated fuel; use fresh fuel • Replace fuel filter • Check and correct fuel pressure
Throttle body <ul style="list-style-type: none"> • Connectors not properly connected 	Air cleaner <ul style="list-style-type: none"> • Clogged air cleaner element • Improper air cleaner installation
COMPRESSION	
Cylinder and cylinder head <ul style="list-style-type: none"> • Weak spark plug • Loose cylinder head • Damaged cylinder head gasket • Damaged cylinder gasket • Worn, damaged or seized cylinder 	Valve system <ul style="list-style-type: none"> • Improperly adjusted valve clearance • Improperly sealed valve • Valve/valves not seating properly • Improper valve timing • Broken valve spring • Seized valve
Piston and Piston ring <ul style="list-style-type: none"> • Worn piston • Worn fatigued or broken piston ring • Seized piston ring • Seized or damaged piston 	

17. TROUBLESHOOTING

IGNITION SYSTEM	
Battery <ul style="list-style-type: none"> • Improperly charged battery • Faulty battery 	Ignition system <ul style="list-style-type: none"> • Faulty igniter unit • Faulty pick up coil • Broken magneto woodruff key
Fuse <ul style="list-style-type: none"> • Burnt out, improper connection 	
Spark plug <ul style="list-style-type: none"> • Improper plug gap • Worn electrodes • Broken connection between ignition coil and spark plug • Incorrect heat range • Faulty spark plug cap 	Faulty switch <ul style="list-style-type: none"> • Faulty main switch • Faulty brake switch
Ignition coil <ul style="list-style-type: none"> • Broken or shorted primary/secondary coil • Faulty high tension cord • Broken ignition coil housing 	Wiring <ul style="list-style-type: none"> • Loose battery terminal • Loose coupler connection • Improperly grounded • Broken wire harness

POOR IDLE PERFORMANCE	
EFI <ul style="list-style-type: none"> • Incorrect fuel pressure • Fuel filter clogged • Fuel injector clogged 	Air cleaner <ul style="list-style-type: none"> • Clogged air cleaner element
Valves <ul style="list-style-type: none"> • Valves improperly adjusted • Incorrect valve clearance 	Ignition system <ul style="list-style-type: none"> • Faulty spark plug • Faulty high tension cord • Faulty igniter unit • Faulty pick up coil • Faulty ignition coil

17. TROUBLESHOOTING

POOR MEDIUM AND HIGH SPEED PERFORMANCE	
Air cleaner <ul style="list-style-type: none"> • Clogged air cleaner element 	
EFI <ul style="list-style-type: none"> • Incorrect fuel pressure • Fuel filter clogged • Fuel injector clogged 	

POOR SPEED PERFORMANCE	
Ignition system <ul style="list-style-type: none"> • Dirty spark plug • Improper spark plug heat range • Faulty igniter unit • Faulty pick up coil 	Compression system <ul style="list-style-type: none"> • Worn cylinder • Worn or seized piston ring • Damaged cylinder head gasket • Damaged cylinder gasket • Carbon deposit buildup • Improper valve clearance • Improper contact between valve and valve seat • Faulty valve timing
Fuel system <ul style="list-style-type: none"> • Clogged fuel tank breather hole • Clogged air cleaner element • Fuel filter clogged • Incorrect fuel pressure 	Clutch <ul style="list-style-type: none"> • Refer to "CLUTCH SLIPPING" section.
Engine oil <ul style="list-style-type: none"> • Improper oil level (too low or too high). 	Ignition system <ul style="list-style-type: none"> • Faulty spark plug • Faulty high tension cord • Faulty igniter unit • Faulty pick up coil • Faulty ignition coil
Valve system <ul style="list-style-type: none"> • Improperly adjusted valve clearance 	

17. TROUBLESHOOTING

ENGINE OVERHEATING	
Ignition system <ul style="list-style-type: none"> • Improper spark plug gap • Improper spark plug heat range • Faulty igniter unit 	
Compression system <ul style="list-style-type: none"> • Heavy carbon deposits build-up • Improperly adjusted valve timing • Improperly adjusted valve clearance 	
Engine oil <ul style="list-style-type: none"> • Incorrect engine oil level • Incorrect oil viscosity (too high) • Degraded engine oil 	

Brakes

- Dragging brake(s)

FAULTY CLUTCH	
ENGINE RUNS BUT ATV WON'T MOVE	
V-belt <ul style="list-style-type: none"> • Worn/bent/slipping 	POOR HIGH SPEED PERFORMANCE
	V-belt <ul style="list-style-type: none"> • Worn • Oil on V-belt
Cam, slider <ul style="list-style-type: none"> • Worn/damaged 	
Compression spring <ul style="list-style-type: none"> • Damaged 	Roller weight <ul style="list-style-type: none"> • Worn/improper operation of primary/secondary sheave • Worn
Front / Rear gearcase <ul style="list-style-type: none"> • Damaged 	

17. TROUBLESHOOTING

CLUTCH SLIPPING

Clutch weight spring

- Worn/loose

CVT Clutch

- Worn/ damaged

Primary sliding sheave

- Seized

POOR STARTING	POOR BRAKING PERFORMANCE
V-belt <ul style="list-style-type: none"> • Worn front hub bearing • Slipping/oiled V-belt 	<ul style="list-style-type: none"> • Worn brake pad(s) • Worn brake disc(s) • Air in brake system • Leaking brake fluid
Primary sliding sheave <ul style="list-style-type: none"> • Improper operation • Damaged 	<ul style="list-style-type: none"> • Faulty master cylinder • Faulty caliper seal • Loose union bolt • Damaged brake hose(s)
Compression spring <ul style="list-style-type: none"> • Worn/loose 	<ul style="list-style-type: none"> • Oily or greasy brake pad(s) • Oily or greasy brake disc(s)
Secondary sliding sheave <ul style="list-style-type: none"> • Improper operation • Worn guide pin groove • Worn guide pin 	
CVT Clutch <ul style="list-style-type: none"> • Worn/ bent 	

18. TOOLS SUPPLIED WITH THE VEHICLE

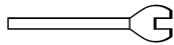
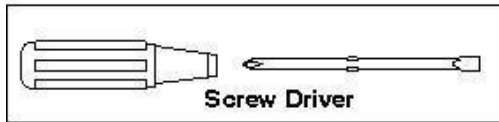

Plastic Expansion Screws Disassembly Tool

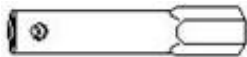

Spark Plug Wrench



Wrench (8, 12mm)



Wrench (10, 14mm)

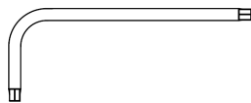

Allen Wrench T30

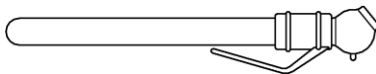

Tire Pressure Gauge

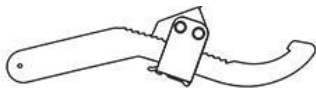

Shock Absorber Adjusting Wrench

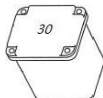

Fuse (30A, Pink)

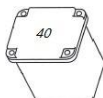

Fuse (40A, Green)

19. SPECIFICATIONS

Linhai Landforce 550

Dimensions & Capacities		
L x W x H	2395 x 1185 x 1390 mm	
Seat height	890 mm	
Wheel Base	1470 mm	
Turning Radius	3800 mm	
Ground Clearance	270 mm	
Fuel capacity	22 L	
Engine Oil Capacity	2.2 L	
Dry Weight	385 kg	
Cargo Racks Maximum load limit	Front: 10 kg Rear: 20 kg	
Load Capacity (Combined Rider & Payload)	180 kg	
Gross Vehicle Weight (Maximum Technically Permissible Mass)	565 kg	
Drive System		
Front Tire	AT25 x 8-12	
Rear Tire	AT25 x 10-12	
Tire Pressure (front)	48.3 kPa	
Tire Pressure (rear)	48.3 kPa	
Brake System		
Brake	Front Brake	Dual Hydraulic Disc
	Rear Brake	
Parking Brake	Mechanical Disc	
Suspension		
Front	Double A-arm independent suspension	
Rear	Double A-arm independent suspension	
Shock absorber	Coil spring	

19. SPECIFICATIONS

Engine	
Engine Type	Single cylinder, liquid cooling, 4 stroke, SOHC
Displacement	493 cm ³
Bore x Stroke	87.5 x 82 mm
Compression Ratio	10.2 : 1
Maximum Power	26.1 kW / 6250 rpm
Maximum Torque	42.6 Nm / 5000 rpm
Cooling System	Liquid
Fuel System	Bosch® EFI
Starting System	Electric
Transmission	CVT; L/H/N/R; gear shifted
Maximum Speed	60 km/h
Drive System	2WD/4WD/4WD/F-Lock

Electrical System			
Battery		12V 20Ah (12V 30Ah for EPS model)	
Headlights – High Beam		LED x2	
Headlights – Low Beam		LED x2	
Front position lamp		LED x2	
Front turn signal		LED x2	
Brake/ Tail Light		LED x2	
Rear turn signal		LED x2	
Fuses	Signal B	15 A	In the Fuse Box
	12V Power Socket	15 A	
	Lamp	15 A	
	EFI	15 A	
	FAN	15 A	
	Fuel Pump	10 A	
	Signal A	10 A	
	EFI	5 A	
	Main Fuse	30 A	
	EPS	40 A	
	Regulator	30 A	

Official distributor:



ASP Group s.r.o.

Staroplzenecka 290

326 00 Letkov

Czech Republic

Phone: +420 378 21 21 21

info@aspgroup.cz

www.aspgroup.eu

Linhai Power Machinery Group Co.,Ltd. reserves the right to change specifications and product design without prior notice. In case of questions, please contact your local Linhai dealer.

© Copyright 2025 ASP Group s.r.o.

All rights reserved. No part of this manual may be reproduced, reprinted, stored in data processing systems, or transmitted in any form or by electronic, mechanical, photographic or other means, transcribed, translated, modified, abbreviated or distributed in whole or in part without specific prior written consent of ASP Group s.r.o.