

**WARNING :**

**Read this Manual,  
and any  
Supplements  
Carefully  
Before Operating  
Vehicle.**

- Assembly
- Operation
- Maintenance

*OWNER'S/OPERATOR'S  
MANUAL*

**Europe 25.0**



**T-Boss 670**

**( Independent Rear Suspension)**

**BEFORE OPERATING THIS VEHICLE, THE OWNER AND EACH OPERATOR MUST HAVE READ AND HAVE AN UNDERSTANDING OF ALL THE INSTRUCTIONS FOR PROPER ASSEMBLY AND SAFE OPERATION, AS WELL AS THE INSTRUCTIONS CONCERNING THE ENGINE AND ALL OTHER PORTIONS OF THE VEHICLE.**

**NOTE:** A storage area/toolbox has been provided on the UTV for storage of this manual, and addendums.

Please keep this manual and addendums in the glove compartment so that it can be found easily and referenced when needed.

---



## **WARNING**

The engine exhaust from this product contains chemicals known, in certain quantities, to cause cancer, birth defects or other reproductive harm.

---

# CONTENTS

1. INTRODUCTION .....	1.1
2. UNDERSTANDING WARNINGS .....	2.1
3. SAFETY WARNING.....	3.1
4. DAILY PRE-RIDE INSPECTION.....	4.1
5. OPERATION WARNING.....	5.1
6. V.I.N. AND ENGINE SERIAL NUMBER.....	6.1
7. CONTROL AND FUNCTIONS.....	7.1
8. STARTING THE ENGINE.....	8.1
9. VEHICLE BREAK-IN PERIOD.....	9.1
10. RIDING GEAR.....	10.1
11. CARRYING LOADS.....	11.1
12. DRIVING.....	12.1
13. CVT SYSTEM.....	13.1
14. BATTERY.....	14.1
15. EXHAUST SYSTEM.....	15.1
16. MAINTENANCE.....	16.1
17. TROUBLE SHOOTING.....	17.1
18. TOOL.....	18.1
19. SPECIFICATION.....	19.1
20. WIRING DIAGRAM.....	20.1

**OWNER'S/OPERATOR'S MANUAL Europe 25.0**

# **1. INTRODUCTION**

---

## **Introduction**

Congratulations on the purchase of your Utility Vehicle (UTV). We take pride in offering you this product engineered and manufactured to the highest performance and quality standards. We are sure that you will enjoy superior levels of performance, reliability, riding comfort, and safety.

This manual is provided to help the owner and operators of this UTV become familiar with the operating characteristic, and the many features offered on the UTV. The manual also covers information on the care and maintenance of your UTV.

Please read this manual carefully. The information contained in this Owner's Manual, the Warning Labels supplied with this product will help you to understand the safe use and maintenance of your UTV. Make sure that you understand and follow all Warnings and Instructions in this material.

If you did not receive any of the material listed above, please call your dealer and request to have them sent to you.

## **1. INTRODUCTION**

---

### **Important Safety Notice**

- This vehicle is designed and manufactured for off-road use.
- Check the laws and regulations in force before choosing where to operate this vehicle. It is illegal to operate this vehicle on public lands where vehicles its size are prohibited.
- Never make any modifications to the engine, drive system, mechanical or electrical systems of your UTV. Never install aftermarket parts or accessories intended to increase the speed or power of your UTV.
- Failure to follow these warnings increases the possibility of accidents leading to **DEATH** or **SERIOUS INJURY!**
- Additionally, failure to follow these requirements will void the Warranty on your UTV.

#### **NOTE**

The addition and use of certain accessories including, (but not limited to) mowers, blades, sprayers, winches and windshields will change the handling characteristics and the performance of your UTV.

### **Practice Responsible UTV Riding**

Make sure that you understand and follow all local, state/province, and federal/national riding laws and requirements.

Remember.....Respect your vehicle, respect the environment and respect the property of others. You are responsible for your safety and the safety of others around you when you ride!

A UTV CAN BE HAZARDOUS TO OPERATE. A UTV handles

## 1. INTRODUCTION

differently from other vehicles including motorcycles, ATVs and cars. A collision rollover can occur quickly, even during routine maneuvers such as turning and driving on hills or over obstacles, if you fail to take proper precautions.



**SERIOUS INJURY OR DEATH** can result if you do not follow these instructions.

- Read this manual and all labels carefully and follow the operating procedures described.
- This vehicle is designed to carry the driver and one passenger. Never carry passengers in the cargo bed.
- Always be sure the driver and passenger are wearing seat belts.
- Never allow anyone who is not an adult to operate this UTV.
- Never permit a guest to operate this UTV unless the guest has read this manual and all product labels.
- The driver and passenger must wear approved off-road motorcycle -type helmets that fits properly. The driver and passenger should also wear eye protections (goggles or face shields), gloves, boots, long-sleeved shirts or jackets, and long pants.
- As with any off-road-capable vehicle, there is a risk of tip over or rollover under certain conditions. Uneven terrain or slopes which pitch the vehicle sideways, turning too fast or sharp, or a combination of conditions increase the risk of tip over.  
If you are in a situation where the vehicle is tipping over, do not put your arm and leg outside the vehicle, do not try to stop tipping with your arm or leg. You could be severely injured. You could suffer a crushed hand, arm, leg, or foot, if part of your body is caught underneath the vehicle.  
You must keep your arms and legs inside the vehicle until it has stopped moving.
- Never consume alcohol or drugs before or while operating this UTV.
- Never operate at excessive speeds. Always travel at a speed which is proper for the terrain, visibility and operating conditions, and your experience.
- Never attempt wheelies, jumps or other stunts.
- Always inspect your UTV each time you use it to make sure it is in safe operating condition. Always follow the inspection and maintenance procedures and schedules described in this manual.
- Always keep both hands, arms, feet, and legs inside the vehicle at

## 1. INTRODUCTION

---

all times during operation. Keep your feet on the floorboard. Never hold onto the enclosure except when using the handgrip inside the enclosure. Otherwise, your hand could be injured if it is caught between the enclosure and an obstacle outside the vehicle.

- Always keep both hands on the steering wheel when driving.
- Never wrap your thumbs and fingers around the steering wheel. This is particularly important when driving in rough terrain. The front wheels will move right and left as they respond to the terrain, and this movement will be felt in the steering wheel. A sudden jolt could wrench the steering wheel around, and your thumbs or fingers could be injured if they are in the way of the steering wheel spokes.
- Always go slowly and be extra careful when operating on unfamiliar terrain. Always be alert to changing terrain conditions when operating the UTV.
- Never operate on excessively rough, slippery or loose terrain.
- Always follow proper procedures for turning as described in this manual. Practice turning at low speeds before attempting to turn at faster speeds. Do not turn at excessive speed.
- Always have the UTV checked by an authorized dealer if it has been involved in an accident.
- Never operate UTV on hills too steep for the UTV or for your abilities. Practice on smaller hills before attempting larger hills.
- Always follow proper procedures for climbing hills as described in this manual. Check the terrain carefully before you start up any hill. Never climb hills with excessively slippery or loose surfaces. Never open throttle suddenly or make sudden gear changes. Never go over the top of any hill at high speed.
- Always follow proper procedures for going down hills and for braking on hills as described in this manual. Check the terrain carefully before you start down any hill. Never go down a hill at high speed. Avoid going down a hill at an angle which would cause the vehicle to lean sharply to one side. Go straight down the hill where possible.
- Always follow proper procedures for crossing the side of a hill as described in this manual. Avoid hills with excessively slippery or loose surfaces. Never attempt to turn the UTV around on any hill. Avoid crossing the side of a steep hill if possible.
- Always use proper procedures if you stall or roll backwards when climbing a hill. To avoid stalling, maintain a steady speed when climbing a hill. If you stall or roll backwards, follow the special procedure for braking described in this manual.

## **1. INTRODUCTION**

---

- Always check for obstacles before operating in a new area. Never attempt to operate over large obstacles, such as large rocks or fallen trees. Always follow proper procedures when operating over obstacles as described in this manual.
- Always be careful of skidding or sliding. On slippery surfaces, such as ice, go slowly and be very cautious in order to reduce the chance of skidding or sliding out of control.
- Avoid operating the UTV through deep or fast flowing water. Avoid water which exceeds the recommended maximum depth. Go slowly, carefully avoiding sudden movements, maintain a slow and steady forward motion, do not make sudden turns or stops, and do not make sudden throttle changes.
- Wet brakes may have reduced stopping ability. Test your brakes after leaving water. If necessary apply them lightly several times to let friction dry out the pads.
- Always be sure there are no obstacles or people behind you when you operate in reverse. When it is safe to proceed in reverse, go slowly. Avoid turning at sharp angles in reverse.
- Always use the size and type tires specified in this manual. Always maintain proper tire pressure as described in this manual.
- Never modify A UTV through improper installation or use of accessories
- Never exceed the stated load capacity. Cargo should be as far forward in the bed as possible, and distributed evenly from side to side. Be sure cargo is secured so that it cannot move around during operation. Reduce speed and follow instructions in this manual for carrying cargo or pulling a trailer. Allow greater distance for braking.

## 2. UNDERSTANDING WARNINGS

---

### ATTENTION:

This is an ADULT VEHICLE ONLY! Not a toy! READ AND UNDERSTAND WARNINGS AND OWNER'S MANUAL BEFORE OPERATION.



**KNOW YOUR VEHICLE BEFORE YOU BEGING RIDING!**

Read this manual thoroughly referring to the various areas which are being discussed on your machine. Operating this vehicle carries with it responsibilities for your personal safety, the safety of others, and the protection of our environment.

---

NOTE: Illustrations used in this manual are for general representation only. Your model may differ.

---

## 2. UNDERSTANDING WARNINGS

---

### SAFETY ALERT

**WARNINGS** identify special instructions or procedures which, if not correctly followed, could result in personal injury, or loss of life. Read all **WARNINGS** in this manual carefully. Follow their instructions to remain safe.

The following precautionary signal words are used throughout this manual to convey the following messages:

 This is the safety alert symbol. When you see this symbol on your machine or in this manual, be alert to the potential for personal injury. Your safety is involved!

 **WARNING**

 **CAUTION**

Indicates a potential hazard which could result in severe injury or death. Indicates a potential hazard which may result in minor personal injury or damage to the UTV.

---

**CAUTION**

Indicates a situation that can result in damage to the machine.

---

**NOTE** The word “NOTE” in this manual will alert you to key information or instructions.

### 3. SAFETY WARNING

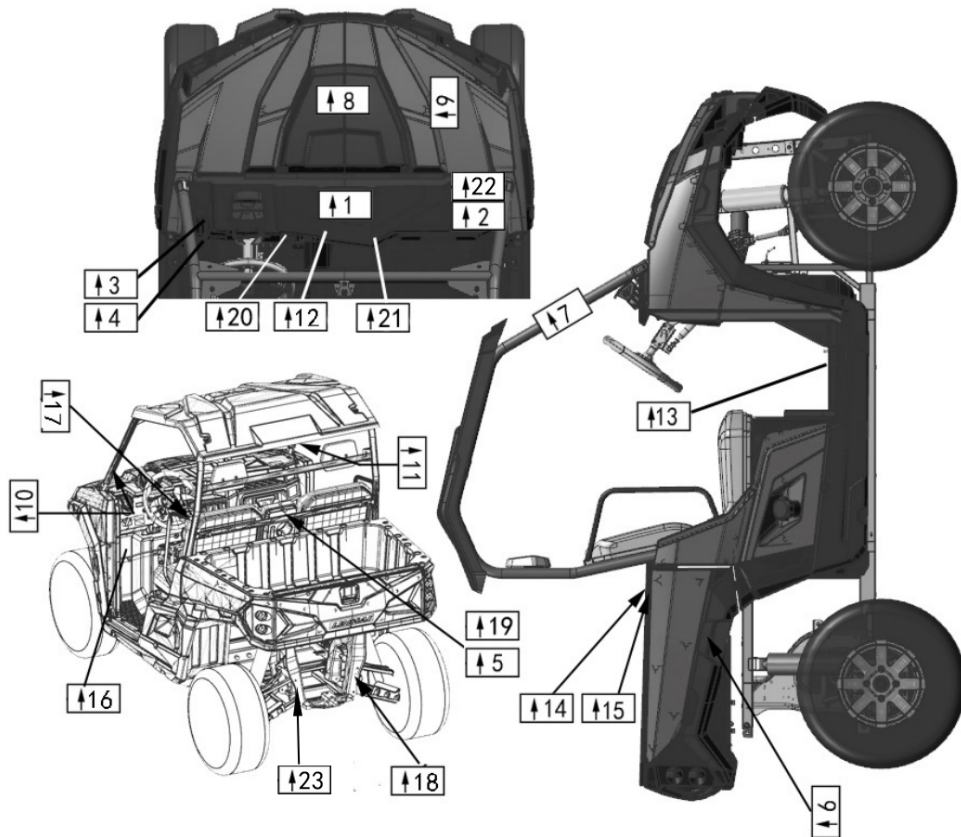

**NOTE :**

Warning decals have been placed on the vehicle for your protection. Read and follow the instructions on each decal carefully. In the event any decal becomes illegible or comes off, contact your dealer for a replacement.

**Attention:** There is a risk of fire from driving the vehicle on the ground where grass has dried up or parking the vehicle on such surface while the engine is hot.

### 3. SAFETY WARNING

1

**WARNING**

Improper Use of Vehicles Can Cause Severe Injury or Death

**Be Prepared**

- Fasten seat belts.
- Wear an approved helmet and protective gear.
- Reserved for message about other occupant restraint devices.
- Each rider must be able to sit with back against seat, feet flat on floor and foot rests, and hands on steeringwheel or handhold where equipped . Stay completely inside the vehicle.

**Drive Responsibly**

Avoid loss of control and rollovers:

- Avoid abrupt maneuvers, sideways sliding, skidding, or fishtailing, and never do donuts.
- Slow down before entering a turn.
- Avoid hard acceleration when turning, even from a stop.
- Plan for hills, rough terrain, ruts, and other changes in traction and terrain. Avoid paved surfaces.
- Avoid side hilling( riding across slopes).

Rollovers have caused severe injuries and death, even on flat, open areas.

**Be Sure Riders Pay Attention and Plan Ahead**

If you think or feel the vehicle may tip or roll, reduce your risk to injury:

- Keep a firm grip on the steering wheel or handholds and brace yourself.
- Do not put any part of your body outside of the vehicle for any reason.

**Require Proper Use of Your Vehicle**

Do your part to prevent injuries:

- Do not allow careless or reckless driving.
- Make sure operators are 16 or older with a valid driver's license .
- Do not let people drive or ride after using alcohol or drugs.
- Do not exceed seating capacity: one passenger.

LOCATE AND READ THE OWNER'S MANUAL FOLLOW ALL INSTRUCTION AND WARNINGS

RESERVED FOR REFERENCE TO OTHER SOURCE OF SAFETY INFORMATION

T02789

2

**WARNING**

**Improper tire pressure or overloading can cause loss of control.**

**Loss of control can result in severe injury or death.**

- **Tire size :**  
 Front : 27 x 9 - 14  
 Rear : 27 x 11 - 14
- **Cold tire pressure:**  
 Front : 14.0 psi (97 kPa)  
 Rear : 14.0 psi (97 kPa)
- **Maximum weight capacity: 661 lbs (300 kg)**

T03017

**NOTE :** Maximum tire pressure: Front : 24psi(170kPa)  
 Rear : 22psi(150kPa)

### 3. SAFETY WARNING

---

3

 **WARNING**

Turning the vehicle in 4WD-LOCK ("DIFF.LOCK") takes more effort. Operate at a slow speed and allow extra time and distance for maneuvers to avoid loss of control.

T02790

4

**NOTE**

Check engine oil every 500 kilometers (310 miles)

T02744

5

**NOTE**

Do not use cup holders while riding in rough conditions.

T02745

6

 **WARNING**



- Keep hands, body, other persons away when closing bed.
- Do not operate the vehicle with bed up.

T02051

7

 **WARNING**

The enclosure cannot protect occupants in all foreseeable accidents, including rollover.

T02049

### 3. SAFETY WARNING

8

 <b>WARNING</b>	
<p>Do not remove the radiator cap when the engine and radiator are hot. Scalding hot fluid and steam may be blown out under pressure, which could cause serious injury. When the engine has cooled, open the radiator cap as follows: Place a thick rag or a towel over the radiator cap. Slowly rotate the cap counterclockwise toward the detent. This allows any residual pressure to escape. When any hissing sound has stopped, press down on the cap while turning counterclockwise and remove it.</p>	T02015



9

 <b>CAUTION</b>	
<p><b>Engine/Radiator Coolant Only Ethylene Glycol and Water Mix.</b></p> <p>Note: Always follow the coolant manufacturer's mixing recommendations for the freeze protection required in your area.</p>	T02022

10

 <b>WARNING</b>	
	<p>You could be severely injured if you try to stop a vehicle tip over using your arm or leg, if vehicle starts to tip over, keep arms and legs inside vehicle.</p> <p>Slopes, uneven terrain, and turning too fast or sharp increase the risk of tip over.</p>
	T02054

11

 <b>WARNING</b>	
	<p>You could be severely injured if you try to stop a vehicle tip over using your arm or leg, if vehicle starts to tip over, keep arms and legs inside vehicle.</p> <p>Slopes, uneven terrain, and turning too fast or sharp increase the risk of tip over.</p>
	T02055

### 3. SAFETY WARNING

12



13



14

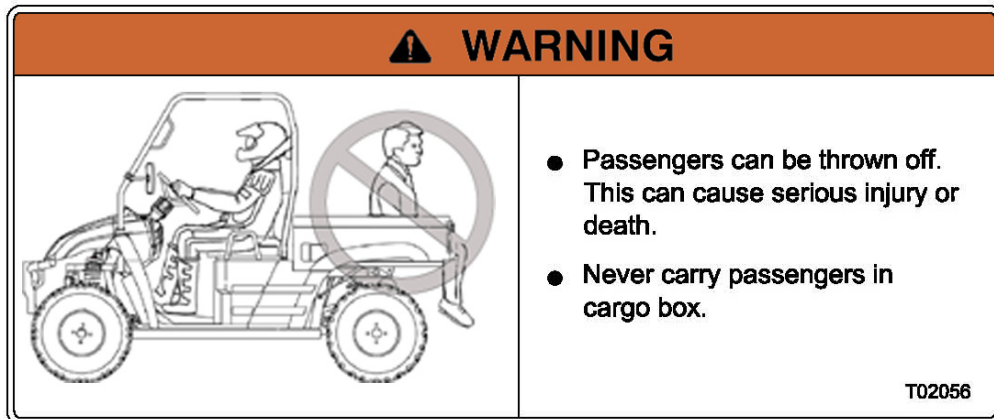

15

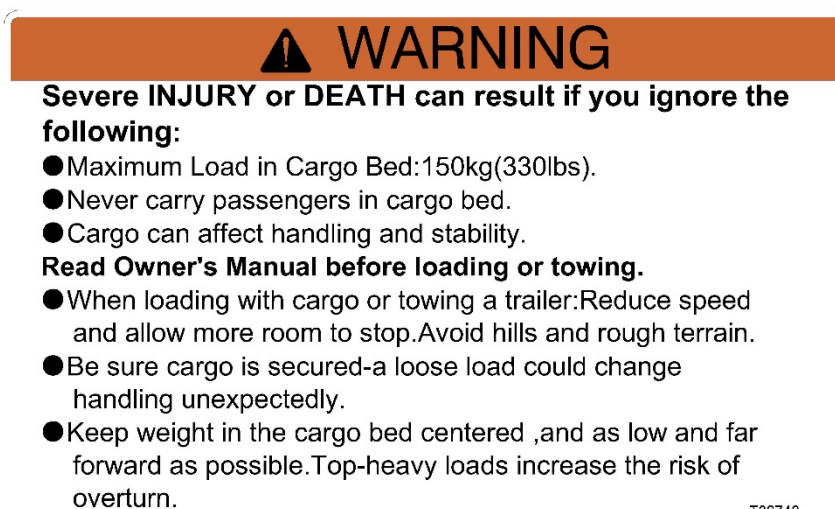

### 3. SAFETY WARNING

16

⚠ **WARNING**

- Operate at a slow speed and allow extra time and distance for maneuvers to avoid loss of control.
- Do not switch on 4WD/2WD if the rear wheels are spinning. This may cause severe machine damage. When switch on 4WD/2WD, the button will stay in 4WD/2WD position but 4WD/2WD mechanics maybe still disengaged. Always apply throttle gently and let the wheels move slightly to allow the 4WD/2WD mechanics finally engage.
- The 4WD/2WD indicator will come on when 4WD/2WD engaged.

T02047

17



⚠ **WARNING**

Always dismount the canopies while the vehicles are transported in a trailer on the expressway so as to avoid personal injury or causing serious traffic accident.

T02628

18

⚠ **WARNING**

Pulling excessive loads can cause loss of stability or control of the vehicle.

Do not exceed the load capacity for the hitch.

Trailer Load Capacity of this vehicle is 1069lbs /485kg and 22lbs/ 10kg tongue weight.

T02956

### 3. SAFETY WARNING

---

19

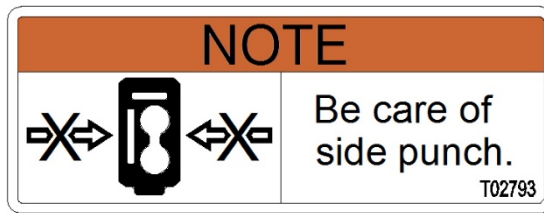

20

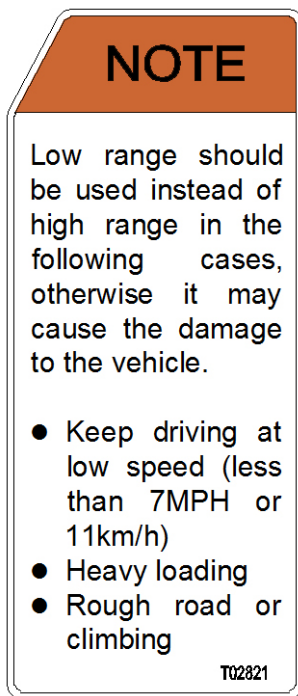

21

(option)

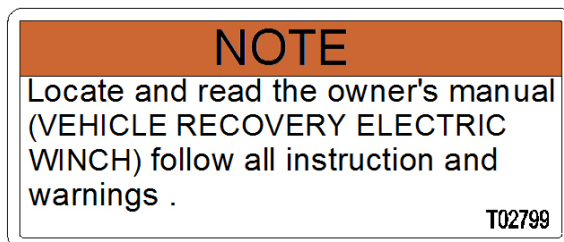

### 3. SAFETY WARNING

---

22

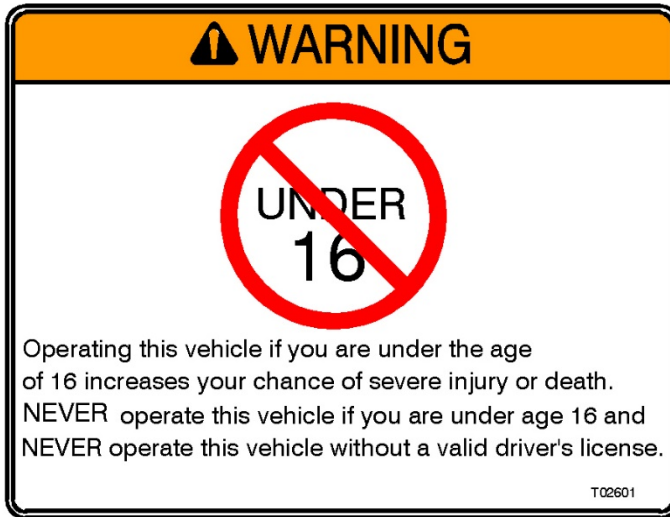

23

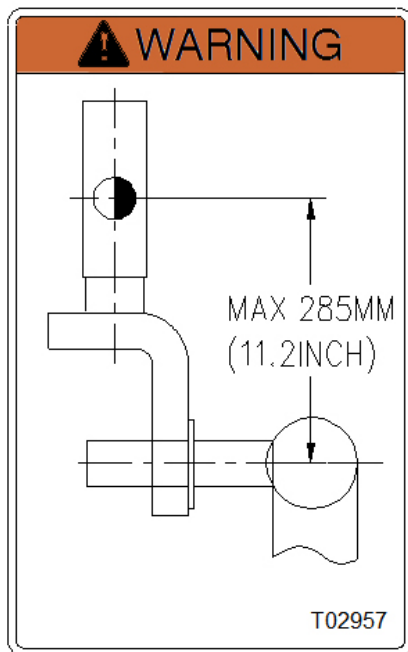

## 4. DAILY PRE-RIDE INSPECTION

---



### WARNING

You must inspect your UTV each time before riding to ensure it is in proper working order. If proper inspection is not done, severe injury or death could result.

---

Use the following checklist to verify your machine is in proper working order each time you ride.

### ITEM/ INSPECTION PROCEDURE

**1, Tire**— check condition and pressures.

**2, Fuel tank**— checking for leaking, fill the fuel tank to its proper level.

**3, All brakes**— check fluid level, check operation, adjustment (includes parking brake).

- Brake pedal

Check for correct brake pedal free play. If the brake pedal free play is incorrect, have an authorized dealer adjust it. Check the operation of the brake pedal. It should move smoothly and there should be a firm feeling when the brakes are applied. If not, have the vehicle inspected by your dealer.

- Brake fluid leakage

Check to see if any brake fluid is leaking out of the pipe joints or the brake fluid reservoir. Apply the brakes firmly for one minute. If there is any leakage, have the vehicle inspected by an authorized dealer.

- Brake fluid level

Check the brake fluid level.

Add fluid if necessary.

- Brake operation

Test the brakes at slow speed after starting out to make sure they are working properly. If the brakes do not provide proper braking performance, inspect the brake system.

**4, Throttle/ Accelerator pedal**— check for free operation, closing and free play.

Check to see that the accelerator pedal operates correctly. It must operate smoothly and fully spring back to the idle position when

## 4. DAILY PRE-RIDE INSPECTION

---

released.

Have an authorized dealer repair as necessary for proper operation.

**5, Headlight / Taillight / Brake light**— check operation of all indicator lights and switches.

**6, Wheels**— check for tightness of wheel nuts and axle nuts; check those axle nuts are secured.

Check balance/ damage/ runout. Have an authorized dealer repair/ replace if necessary.

Check bearing assemblies for looseness/damage. Have an authorized dealer replace if damaged.

**7, Air cleaner element**— check for dirt; clean or replace.

**8, Steering**— check for free operation noting any unusual looseness in any area.

Park on level ground. Turn the steering wheel right and left. Check for excessive free play, abnormal noises, or a rough feeling. Have an authorized dealer repair as necessary for proper operation.

**9, Loose parts**— visually inspect vehicle for any damaged components or loose nuts/bolts or fasteners.

Always check the tightness of chassis fittings and fasteners before a ride. Take the vehicle to your dealer for correct tightening torque.

**10, Operator's and passenger's helmets, goggles and clothing.**

**11, Engine coolant**— check for proper level at the recovery bottle.

**12, Seat belts**— Check for proper operation and belt wear.

Make sure that both seat belts are not frayed or damaged. The seat belt must move smoothly when pulled out and retract on its own when released. The latch plate should click securely into the buckle and release when the release button is pushed firmly. Clean off any dirt or mud which could affect operation. Have an authorized dealer repair as necessary for proper operation.

## 5. OPERATION WARNINGS

---



### WARNING

#### **POTENTIAL HAZARD**

Improper handling of gasoline.

#### **WHAT CAN HAPPEN**

Gasoline can catch fire and you could be burned.

#### **HOW TO AVOID THE HAZARD**

Always turn off the engine when refueling. Do not refuel right after the engine has been running and is still very hot. Do not spill gasoline on the engine or exhaust pipe/muffler when refueling. Never refuel while smoking, or while in the vicinity of sparks, open flames, or other sources of ignition such as the pilot lights of water heaters and clothes dryers.



### WARNING

#### **POTENTIAL HAZARD**

Checking the fuel system while smoking or near an open flame.

#### **WHAT CAN HAPPEN**

Fuel can ignite or explode, causing severe injury or property damage.

#### **HOW TO AVOID THE HAZARD**

Do not smoke when checking the fuel system. Make sure there are no open flames or sparks in the area, including pilot lights from water heaters or furnaces.

## 5. OPERATION WARNINGS

---



### WARNING

#### **POTENTIAL HAZARD**

When transporting the vehicle in another vehicle, be sure it is kept in an upright position. Otherwise, fuel may leak out of the fuel tank.

#### **WHAT CAN HAPPEN**

Gasoline is poisonous and can cause injuries.

#### **HOW TO AVOID THE HAZARD**

If you should swallow some gasoline or inhale a lot of gasoline vapor, or get some gasoline in your eyes, see your doctor immediately. If gasoline spills on your skin, wash with soap and water. If gasoline spills on your clothing, change your clothes.



### WARNING

#### **POTENTIAL HAZARD**

Changing from 2WD to 4WD or vice-versa while the vehicle is moving.

#### **WHAT CAN HAPPEN**

The vehicle handles differently in 2WD than in 4WD, or vice-versa a while moving may cause the vehicle to unexpectedly handle differently. This could distract the operator and increase the risk of losing control and an accident.

#### **HOW TO AVOID THE HAZARD**

Always stop the vehicle before changing from 2WD to 4WD, or vice-versa.

## 5. OPERATION WARNINGS

---



### WARNING

#### **POTENTIAL HAZARD**

Malfunction of the accelerator pedal.

#### **WHAT CAN HAPPEN**

The accelerator pedal could be hard to operate, making it difficult to speed up or slow down when you need to. This could cause an accident.

#### **HOW TO AVOID THE HAZARD**

Check the operation of the accelerator pedal before you start the engine. If it does not work smoothly, check for the cause. Correct the problem before operating the vehicle. Consult an authorized dealer if you can't find or solve the problem yourself.



### WARNING

#### **POTENTIAL HAZARD**

A loose seat.

#### **WHAT CAN HAPPEN**

The operator could lose control or the operator or passenger could fall if the seat is loose during operation.

#### **HOW TO AVOID THE HAZARD**

Make sure the seat is securely latched.



### WARNING

#### **POTENTIAL HAZARD**

Not wearing the seat belt.

Wearing the seat belt improperly.

#### **WHAT CAN HAPPEN**

There is increased risk of being killed or seriously injured in an accident.

#### **HOW TO AVOID THE HAZARD**

Always wear your seat belt when riding in the vehicle.

Be sure the seat belt is close-fitting across your hips and chest and is latched securely.

## 5. OPERATION WARNINGS

---



### WARNING

#### **POTENTIAL HAZARD**

Try to stop the tipping vehicle with your arm or leg.

#### **WHAT CAN HAPPEN**

You could be severely injured. You could suffer a crushed hand, arm, leg, or foot,

#### **HOW TO AVOID THE HAZARD**

You must keep your arms and legs inside the vehicle until it has stopped moving.

As with any off-road-capable vehicle, there is a risk of tip over or rollover under certain conditions. Uneven terrain or slopes which pitch the vehicle sideways, turning too fast or sharp, or a combination of conditions increase the risk of tip over.

If you are in a situation where the vehicle is tipping over, do not put your arm or/ and leg outside the vehicle, do not try to stop tipping with your arm or leg. You could be severely injured. You could suffer a crushed hand, arm, leg, or foot, if part of your body is caught underneath the vehicle.



### WARNING

#### **POTENTIAL HAZARD**

Pinch points.

#### **WHAT CAN HAPPEN**

You or someone else could be pinched between the cargo bed and the frame when the bed is being lowered.

#### **HOW TO AVOID THE HAZARD**

Before closing the bed, be sure others are standing away from the vehicle. Keep hands and fingers away from the pinch points between the bed and the frame.

## 5. OPERATION WARNINGS

---



### WARNING

#### **POTENTIAL HAZARD**

Overloading the cargo bed

#### **WHAT CAN HAPPEN**

Could cause changes in vehicle handling which could lead to an accident.

#### **HOW TO AVOID THE HAZARD**

Never exceed the stated maximum load limit for this cargo bed.

Cargo should be properly distributed and securely attached.

Reduce speed when carrying cargo. Allow greater distance for braking.



### WARNING

#### **POTENTIAL HAZARD**

Carrying a passenger/ passengers in the cargo bed

#### **WHAT CAN HAPPEN**

The passenger(s) could fall, be thrown out, or be struck by objects in the cargo bed.

#### **HOW TO AVOID THE HAZARD**

Never carry a passenger/ passengers in the cargo bed. This cargo bed is designed to carry cargo only.



### WARNING

#### **POTENTIAL HAZARD**

Improper shock absorber adjustment.

#### **WHAT CAN HAPPEN**

Uneven adjustment can cause poor handling and loss of stability, which could lead to an accident.

#### **HOW TO AVOID THE HAZARD**

Always adjust the shock absorbers on the left and right side to the same setting.

## 5. OPERATION WARNINGS

---



### WARNING

#### **POTENTIAL HAZARD**

Driving with improperly operating brakes.

#### **WHAT CAN HAPPEN**

You could lose braking ability, which could lead to an accident.

#### **HOW TO AVOID THE HAZARD**

Always check the brakes at the start of every ride. Do not operate the vehicle if you find any problem with the brakes. If a problem cannot be corrected by the adjustment procedures provided in this manual, have the vehicle inspected by an authorized dealer.



### WARNING

#### **POTENTIAL HAZARD**

Improper care when refueling.

#### **WHAT CAN HAPPEN**

Fuel can spill, which can cause a fire and severe injury. Fuel expands when it heats up. If the fuel tank is overfilled, fuel could spill out due to heat from the engine or the sun.

#### **HOW TO AVOID THE HAZARD**

Do not overfill the fuel tank. Be careful not to spill fuel, especially on the engine or exhaust pipe. Wipe up any spilled fuel immediately. Be sure the fuel tank cap is closed securely.



### WARNING

#### **POTENTIAL HAZARD**

Removing the radiator cap when the engine and radiator are still hot.

#### **WHAT CAN HAPPEN**

You could be burned by hot fluid and steam blown out under pressure.

#### **HOW TO AVOID THE HAZARD**

Wait for the engine to cool before removing the radiator cap. Always use a thick rag over the cap. Allow any remaining pressure to escape before completely removing the cap.

## 5. OPERATION WARNINGS

---



### WARNING

#### **POTENTIAL HAZARD**

Operating vehicle without being familiar with all controls.

#### **WHAT CAN HAPPEN**

Loss of control, which could cause an accident or injury.

#### **HOW TO AVOID THE HAZARD**

Read the Owner's Manual carefully. If there is a control or function you do not understand, ask our authorized dealer.



### WARNING

#### **POTENTIAL HAZARD**

Freezing control cables in cold weather.

#### **WHAT CAN HAPPEN**

You could be unable to control the vehicle, which could lead to an accident or collision.

#### **HOW TO AVOID THE HAZARD**

When riding in cold weather, always make sure all control cables work smoothly before you begin riding.



### WARNING

#### **POTENTIAL HAZARD**

Overloading this vehicle or carrying or towing cargo improperly.

#### **WHAT CAN HAPPEN**

Could cause changes in vehicle handling which could lead to an accident.

#### **HOW TO AVOID THE HAZARD**

Never exceed the stated load capacity for this vehicle.

Cargo should be properly distributed and securely attached.

Reduce speed when carrying cargo or pulling a trailer. Allow greater distance for braking.

## 5. OPERATION WARNINGS

---



### WARNING

#### **POTENTIAL HAZARD**

Servicing an engine while it is running.

#### **WHAT CAN HAPPEN**

Moving parts can catch clothing or parts of the body, causing injury.

Electrical components can cause shocks or can start fires.

#### **HOW TO AVOID THE HAZARD**

Turn off the engine when performing maintenance unless otherwise specified.

Have an authorized dealer perform service if you are not familiar with vehicle service.



### WARNING

#### **POTENTIAL HAZARD**

Operating this vehicle with improper modifications.

#### **WHAT CAN HAPPEN**

Improper installation of accessories or modification of this vehicle may cause changes in handling which in some situations could lead to an accident.

#### **HOW TO AVOID THE HAZARD**

Never modify this vehicle through improper installation or use of accessories. All parts and accessories added to this vehicle should be genuine parts or equivalent components designed for use on this vehicle and should be installed and used according to instructions. If you have questions, consult an authorized dealer.

## 5. OPERATION WARNINGS

---



### WARNING

#### **POTENTIAL HAZARD**

Using low flash point solvents or gasoline to clean the sponge material.

#### **WHAT CAN HAPPEN**

Low flash point solvents or gasoline can catch fire or explode.

#### **HOW TO AVOID THE HAZARD**

Use parts cleaning solvent to clean the sponge material.



### WARNING

#### **POTENTIAL HAZARD**

Improper cleaning of the spark arrester. Hot exhaust system

#### **WHAT CAN HAPPEN**

Could injure the eyes. Could cause burns.

Could cause carbon monoxide poisoning, possibly leading to death.

Could start a fire.

#### **HOW TO AVOID THE HAZARD**

When cleaning the spark arrester: Always let the exhaust system cool prior to touching exhaust components.

Do not start the engine when cleaning the exhaust system.

## 5. OPERATION WARNINGS

---



### WARNING

#### **POTENTIAL HAZARD**

Operating with improperly serviced or adjusted brakes.

#### **WHAT CAN HAPPEN**

You could lose braking ability, which could lead to an accident.

#### **HOW TO AVOID THE HAZARD**

After servicing:

- Make sure the brakes operate smoothly and that the brake pedal position is correct.
- Make sure the brakes do not drag.
- All air must be bled from the brake system.

Replacement of brake components requires professional knowledge. These procedures should be performed by an authorized dealer.



### WARNING

#### **POTENTIAL HAZARD**

Damaged control cables.

#### **WHAT CAN HAPPEN**

Corrosion can result when the outer covering of control cables becomes damaged. Cables can also become frayed or kinked. Operation of controls could be restricted, which could cause an accident or injury.

#### **HOW TO AVOID THE HAZARD**

Inspect cables frequently. Replace damaged cables.

## 5. OPERATION WARNINGS

---



### WARNING

#### **POTENTIAL HAZARD**

Failure to handle batteries or battery electrolyte carefully.

#### **WHAT CAN HAPPEN**

You could be poisoned. You could be severely burned by the sulfuric acid in battery electrolyte. Batteries produce explosive gases.

#### **HOW TO AVOID THE HAZARD**

Avoid contact with skin, eyes or clothing. Always shield eyes when working near batteries. Keep out of reach of children.

Antidote:

EXTERNAL: Flush with water.

INTERNAL: Drink large quantities of water or milk. Follow with milk of magnesia, beaten egg or vegetable oil. Get prompt medical attention.

EYES: Flush with water for 15 minutes and get prompt medical attention. Keep batteries away from sparks, flames, cigarettes or other sources of ignition. Ventilate when charging or using in a closed space.



### WARNING

#### **POTENTIAL HAZARD**

Using an improper fuse

#### **WHAT CAN HAPPEN**

An improper fuse can cause damage to the electrical system, which could lead to a fire.

#### **HOW TO AVOID THE HAZARD**

Always use a fuse of the specified rating. Never use a material in place of the proper fuse.

## 5. OPERATION WARNINGS

---



### WARNING

#### **POTENTIAL HAZARD**

A headlight bulb is hot when it is on and immediately after it is turned off.

#### **WHAT CAN HAPPEN**

You can be burned, or a fire could start if the bulb touches something flammable.

#### **HOW TO AVOID THE HAZARD**

Wait for the bulb to cool before touching or removing it.



### WARNING

#### **POTENTIAL HAZARD**

Operation with wet brakes after washing.

#### **WHAT CAN HAPPEN**

Wet brakes may have reduced stopping ability, increasing the chance of an accident.

#### **HOW TO AVOID THE HAZARD**

Test the brakes after washing. Apply the brakes several times at slow speeds to let friction dry out the linings.

## 5. OPERATION WARNINGS

---



### WARNING

#### **POTENTIAL HAZARD**

Operating/ riding this UTV without wearing an approved helmet, eye protection and protective clothing.

#### **WHAT CAN HAPPEN**

Operating/ riding without an approved helmet increases your chances of a severe head injury or death in the event of an accident.

Operating/ riding without eye protection can result in an accident and increases your chances of a severe injury in the event of an accident.

#### **HOW TO AVOID THE HAZARD**

Always wear an approved helmet which fits properly.

You should also wear: eye protection (goggles or face shield); gloves; boots; long-sleeved shirt or jacket; and long pants.



### WARNING

#### **POTENTIAL HAZARD**

Operating this UTV after consuming alcohol or drugs.

#### **WHAT CAN HAPPEN**

Could seriously affect your judgment.

Could cause you to react more slowly.

Could affect your balance and perception.

Could result in an accident.

#### **HOW TO AVOID THE HAZARD**

Never consume alcohol or drugs before or while driving this UTV.

## 5. OPERATION WARNINGS

---



### WARNING

#### **POTENTIAL HAZARD**

Operating this UTV at excessive speeds.

#### **WHAT CAN HAPPEN**

Increases your chances of losing control of the UTV, which can result in an accident.

#### **HOW TO AVOID THE HAZARD**

Always travel at a speed which is proper for the terrain, visibility and operating conditions; and your experience.



### WARNING

#### **POTENTIAL HAZARD**

Attempting wheelies, jumps and other stunts.

#### **WHAT CAN HAPPEN**

Increases the chance of an accident, including an overturn.

#### **HOW TO AVOID THE HAZARD**

Never attempt stunts, such as wheelies or jumps.



### WARNING

#### **POTENTIAL HAZARD**

Failure to inspect the UTV before operating.

Failure to properly maintain the UTV.

#### **WHAT CAN HAPPEN**

Increases the possibility of an accident or equipment damage.

#### **HOW TO AVOID THE HAZARD**

Always inspect your UTV each time you use it to make sure the UTV is in safe operating condition.

Always follow the inspection and maintenance procedures and schedules described in the Owner's Manual.

## 5. OPERATION WARNINGS



### WARNING

#### **POTENTIAL HAZARD**

Removing hands from steering wheel or feet from footrests during operation.

#### **WHAT CAN HAPPEN**

Removing even one hand or foot can reduce your ability to control the UTV or could cause you to lose your balance and fall off the UTV.

#### **HOW TO AVOID THE HAZARD**

Always keep both hands on the steering wheel and both feet on the footrests of your UTV during operation.



### WARNING

#### **POTENTIAL HAZARD**

Failure to use extra care when operating this UTV on unfamiliar terrain.

#### **WHAT CAN HAPPEN**

You can come upon hidden rocks, bumps, or holes, without enough time to react.

Could result in the UTV overturning or going out of control.

#### **HOW TO AVOID THE HAZARD**

Go slowly and be extra careful when operating on unfamiliar terrain.

Always be alert to changing terrain conditions when operating the UTV.

## 5. OPERATION WARNINGS



### WARNING

#### **POTENTIAL HAZARD**

Failure to use extra care when operating on excessively rough, slippery or loose terrain.

#### **WHAT CAN HAPPEN**

Could cause loss of traction or vehicle control, which could result in an accident, including an overturn.

#### **HOW TO AVOID THE HAZARD**

Do not operate on excessively rough, slippery or loose terrain until you have learned and practiced the skills necessary to control the UTV on such terrain.

Always be especially cautious on these kinds of terrain.



### WARNING

#### **POTENTIAL HAZARD**

Climbing hills improperly.

#### **WHAT CAN HAPPEN**

Could cause loss of control or cause UTV to overturn.

#### **HOW TO AVOID THE HAZARD**

Always follow proper procedures for climbing hills as described in the Owner's Manual.

Always check the terrain carefully before you start up any hill.

Never climb hills with excessively slippery or loose surfaces.

Never open the throttle suddenly. The UTV could flip over backwards.

Never go over the top of any hill at high speed. An obstacle, a sharp drop, or another vehicle or person could be on the other side of the hill.

## 5. OPERATION WARNINGS



### WARNING

#### **POTENTIAL HAZARD**

Turning improperly.

#### **WHAT CAN HAPPEN**

UTV could go out of control, causing a collision or overturn.

#### **HOW TO AVOID THE HAZARD**

Always follow proper procedures for turning as described in the Owner's Manual.

Practice turning at low speeds before attempting to turn at faster speeds. Do not turn at excessive speed.



### WARNING

#### **POTENTIAL HAZARD**

Operating on excessively steep hills.

#### **WHAT CAN HAPPEN**

The vehicle can overturn more easily on extremely steep hills than on level surfaces or small hills.

#### **HOW TO AVOID THE HAZARD**

Never operate the UTV on hills too steep for the UTV or for your abilities. Practice on smaller hills before attempting large hills. Never operate UTV on hills steeper than 30%.



### WARNING

## 5. OPERATION WARNINGS

---

### **POTENTIAL HAZARD**

Going down a hill improperly.

### **WHAT CAN HAPPEN**

Could cause loss of control or cause UTV to overturn.

### **HOW TO AVOID THE HAZARD**

Always follow proper procedures for going down hills as described in the Owner's Manual. NOTE: A special technique is required when braking as you go downhill.

Always check the terrain carefully before you start down any hill.

Never go down a hill at high speed.

Avoid going down a hill at an angle which would cause the vehicle to lean sharply to one side. Go straight down the hill where possible.



### **WARNING**

### **POTENTIAL HAZARD**

Improperly crossing hills or turning on hills.

### **WHAT CAN HAPPEN**

Could cause loss of control or cause UTV to overturn.

### **HOW TO AVOID THE HAZARD**

Never attempt to turn the UTV around on any hill until you have mastered the turning technique as described in the Owner's Manual on level ground. Be very careful then turning on any hill.

Avoid crossing the side of a steep hill if possible.

### **When crossing the side of a hill:**

Always follow proper procedures as described in the Owner's Manual.

Avoid hills with excessively slippery or loose surfaces.



### **WARNING**

## 5. OPERATION WARNINGS

---

### **POTENTIAL HAZARD**

Stalling, rolling backwards or improperly dismounting while climbing a hill.

### **WHAT CAN HAPPEN**

Could result in UTV overturning.

### **HOW TO AVOID THE HAZARD**

Maintain steady speed when climbing a hill.

If you lose all forward speed:

Keep weight uphill.

Apply the brakes.

Lock parking brake after you are stopped.

If you begin rolling backwards:

Keep weight uphill; never apply engine power.

Apply the brake gradually.

When fully stopped, apply rear brake as well, and then lock parking brake.

Dismount on uphill side, or to either side if pointed straight uphill.



**WARNING**

### **POTENTIAL HAZARD**

Improperly operating over obstacles.

### **WHAT CAN HAPPEN**

Could cause loss of control or a collision. Could cause the UTV to overturn.

### **HOW TO AVOID THE HAZARD**

Before operating in a new area, check for obstacles.

Use extreme caution when riding over large obstacles, such as large rocks or fallen trees.

If you cannot avoid obstacles, always follow proper procedures as described in the Owner's Manual.



**WARNING**

## 5. OPERATION WARNINGS

---

### **POTENTIAL HAZARD**

Skidding or sliding,

### **WHAT CAN HAPPEN**

You may lose control of the UTV.

You may also regain traction unexpectedly, which may cause the UTV to overturn.

### **HOW TO AVOID THE HAZARD**

On slippery surfaces, such as ice, go slowly and be very cautious in order to reduce the chance of skidding or sliding out of control.



**WARNING**

### **POTENTIAL HAZARD**

Operating this UTV through deep or fast flowing water.

### **WHAT CAN HAPPEN**

Tires may float, causing loss of traction and loss of control, which could lead to an accident.

### **HOW TO AVOID THE HAZARD**

Never operating the UTV through water which exceeds the recommended maximum depth in this manual.

Avoid operating the UTV through deep or fast flowing water. If you cannot avoid water, go slowly, balance your weight carefully avoiding sudden movement, maintain a slow and steady forward motion, do not make sudden turns or stops, and do not make sudden throttle changes. Remember that wet brakes may have reduced stopping ability.

Test your brakes after leaving water. If necessary, apply them several times to let friction dry out the pads.



**WARNING**

### **POTENTIAL HAZARD**

## 5. OPERATION WARNINGS

---

Improperly operating in reverse,

### **WHAT CAN HAPPEN**

You could hit an obstacle or person behind you, resulting in severe injury.

### **HOW TO AVOID THE HAZARD**

When you select reverse gear, make sure there are no obstacles or people behind you. When it is safe to proceed, go slowly.



## WARNING

### **POTENTIAL HAZARD**

Operating this UTV with improper tires, or with improper or uneven tire pressure.

### **WHAT CAN HAPPEN**

Use of improper tires on this UTV, or operation of this UTV with improper or uneven tire pressure, may cause loss of control, and increases the risk of an accident.

### **HOW TO AVOID THE HAZARD**

Always use the size and type tires specified in the Owner's Manual for this vehicle.

Always maintain proper tire pressure as described in the Owner's Manual. Use proper pressures stated on the side wall of the tire when seating the tire beads. Higher pressures may cause the tire to burst. Inflate the tires very slowly and carefully. Fast inflation could cause the tire to burst.



## WARNING

### **POTENTIAL HAZARD**

Operating this UTV with improper modifications.

### **WHAT CAN HAPPEN**

## 5. OPERATION WARNINGS

---

Improper installation of accessories or modification of this vehicle may cause changes in handling which in some situations could lead to an accident.

### **HOW TO AVOID THE HAZARD**

Never modify this UTV through improper installation or use of accessories. All parts and accessories added to this vehicle should be genuine or equivalent components designed for use on this UTV; and should be installed and used according to instructions. If you have questions, consult our authorized dealer.



### **WARNING**

### **POTENTIAL HAZARD**

Riding on frozen lakes and rivers.

### **WHAT CAN HAPPEN**

Severe injury or death can result if the UTV and /or the operator break through the ice.

### **HOW TO AVOID THE HAZARD**

Never ride you UTV on a frozen body of water.



### **WARNING**

After a rollover or an accident, have a qualified service dealer check the complete machine including, but not limited to, brakes, throttle and steering for possible damage.

## 5. OPERATION WARNINGS

---



### WARNING

Safe operation of this rider active vehicle requires good judgment and physical skills. Persons with cognitive or physical disabilities who operate this vehicle have an increased risk of overturns and loss of control which could result in severe injury or death.



### CAUTION

Keep combustible materials away from exhaust system. Fire may result.

## 6. V.I.N. AND ENGINE SERIAL NUMBER

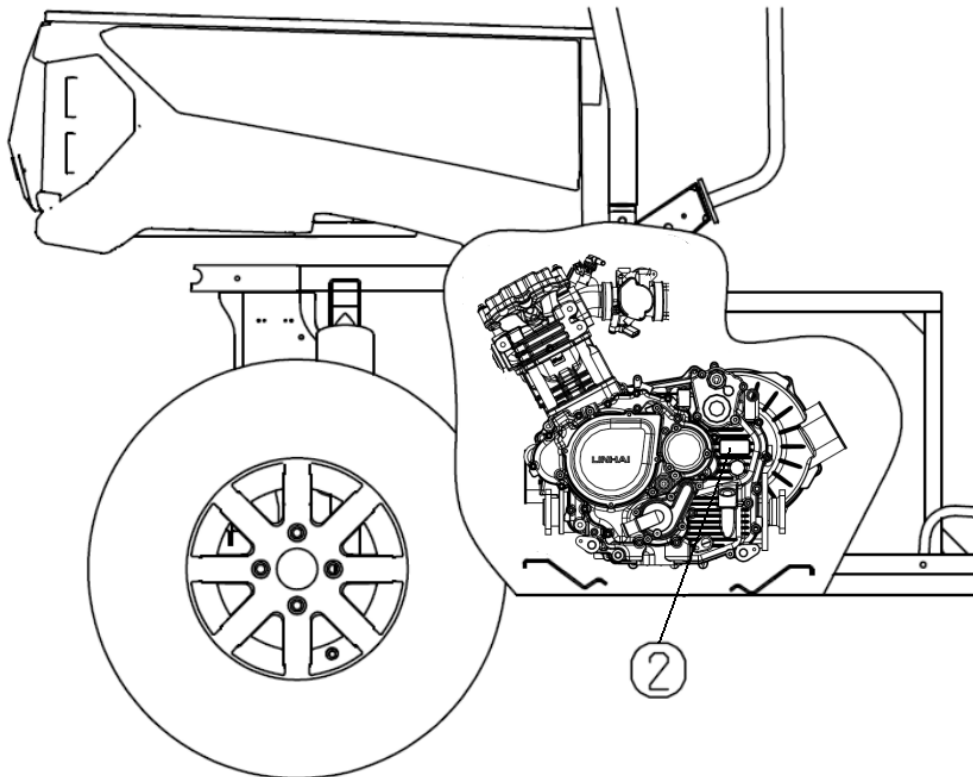
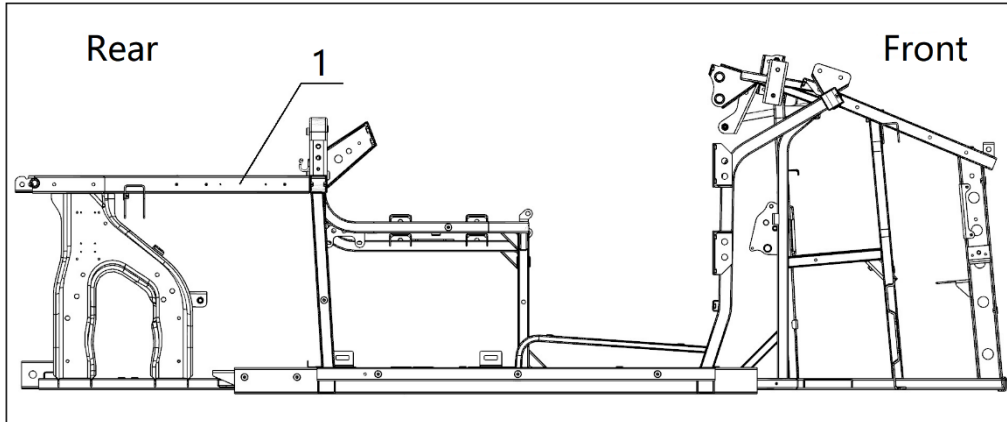

Record the vehicle frame and engine serial numbers from your UTV in



## 7. CONTROL AND PARTS FUNCTIONS

### ELECTRICAL SWITCHES

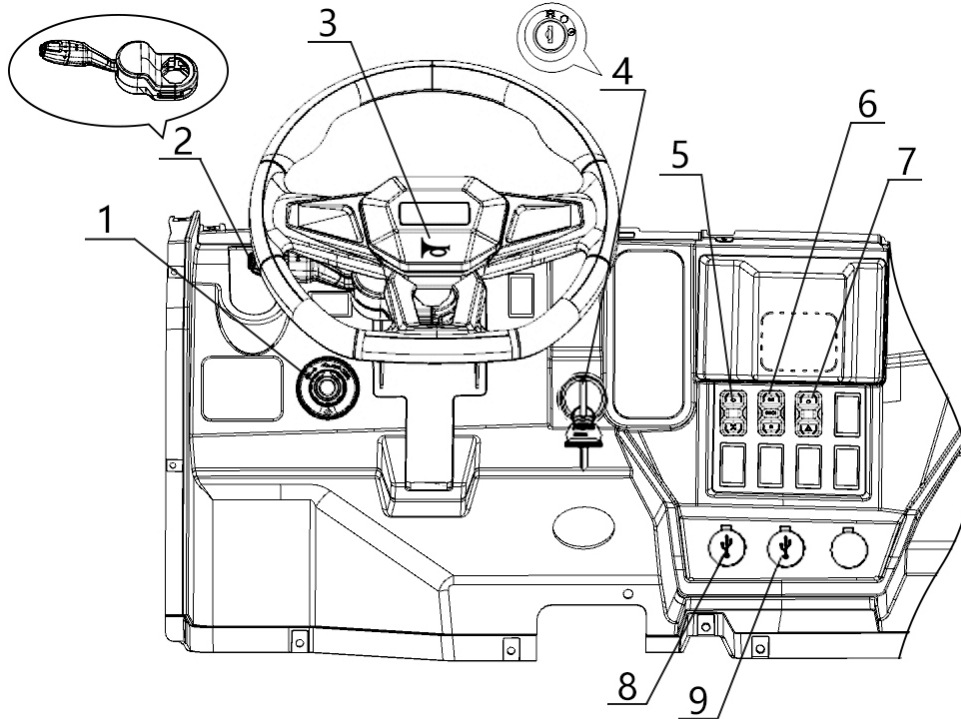

1. 2WD / 4WD /4WD Lock Switch	6.Winch Switch (Option)
2. Light Combination Switch	7.Hazard Switch (Option)
3. Horn Switch	8.USB Outlet
4. Main Switch	9.USB Outlet (Option)
5.Rear Diff Lock Switch	

#### 1. 2WD / 4WD /4WD Lock Switch

This vehicle is equipped with an on-command “2WD” / “4WD” optional “4WD LOCK” switch on the right upper side of the dashboard. Select the appropriate drive mode according to terrain and conditions:

**2WD:** When the switch is on this position, power is supplied to the rear wheels only.

**4WD:** When the switch is on this position, power is supplied to both front and rear wheels.

**4WD-LOCK:** When the switch is on this position, power is supplied to the rear and front wheels and the front differential is locked.

Unlike 4WD, both front wheels turn at the same speed to provide maximum front wheel traction. Turning effort and tire wear will be increased on hard surfaces.

## 7. CONTROL AND PARTS FUNCTIONS



### CAUTION

Always shift as the vehicle stop.

**NOTE:** When shift 2WD / 4WD, the mechanics in the front gear box maybe still engaged / disengaged, the mechanics would finally disengaged / engaged when rides on a hard surface or rides in reverse.



### CAUTION

Do not switch on 4WD if the rear wheels are spinning. This may cause severe machine damage. When switch on 4WD, the button will stay in 4WD position but 4WD mechanics maybe still disengaged. Always apply throttle gently and let the wheels move slightly to allow the 4WD mechanics finally engage. The 4WD indicator on the speedometer will come on when 4WD engaged.

### 2. Light Combination Switch

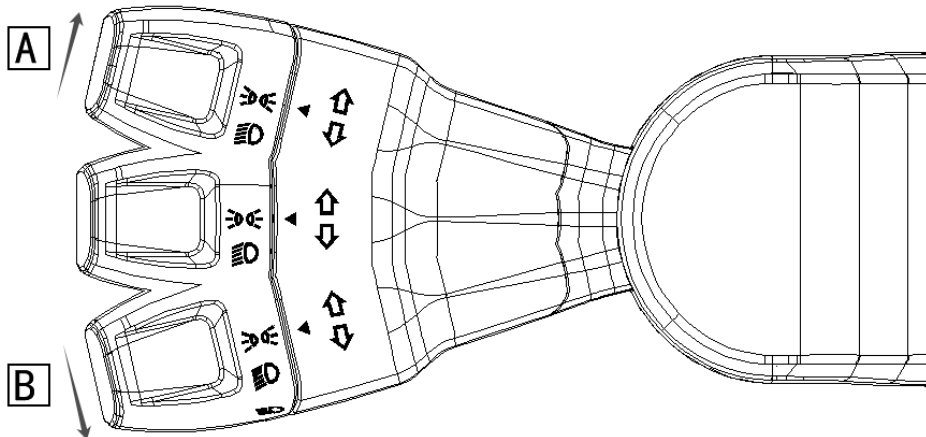

#### Turning Lights Switch

Lift up in arrow direction **A** beyond the point of resistance to activate right turning light flashing. The indicator will flash on the instrument

## **7. CONTROL AND PARTS FUNCTIONS**

---

Toggle the combination switch in reverse to cancel the right turning light.

Push down in arrow direction **B** beyond the point of resistance to activate left turning light flashing. The indicator will flash on the instrument. Toggle the combination switch in reverse to cancel the left turning light.

Dimmer Switch

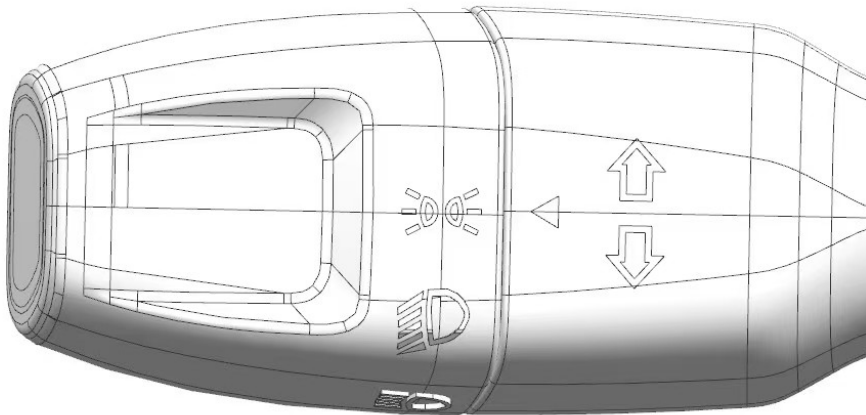



Rotate the knob in the arrow direction to align the icon "  " with

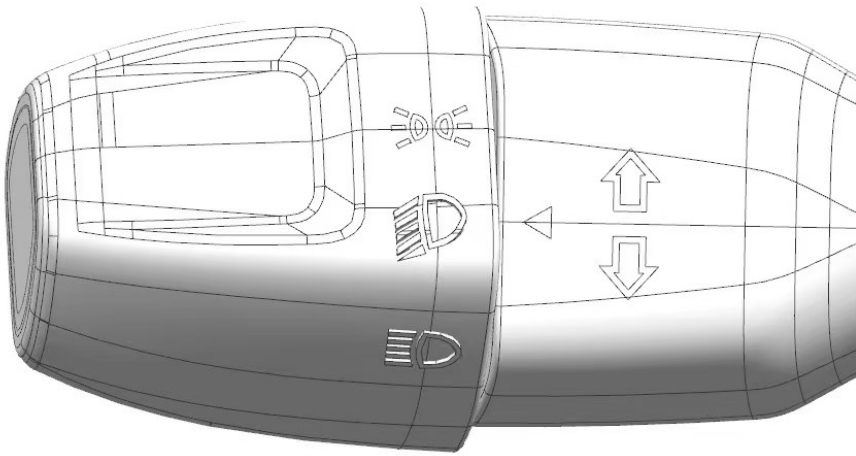

"  " to turn off the headlights.

## **7. CONTROL AND PARTS FUNCTIONS**

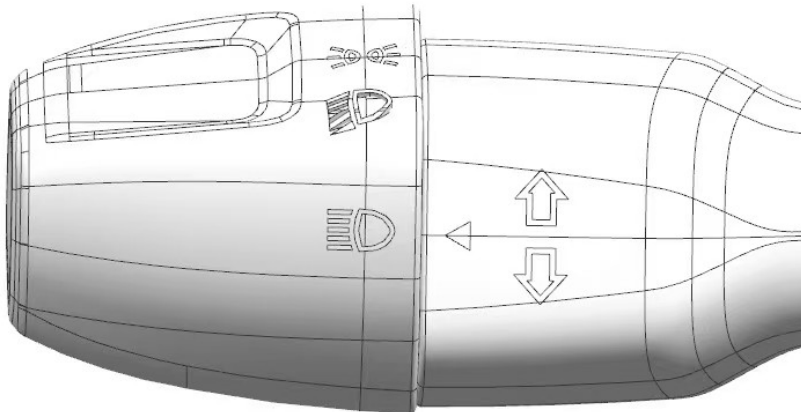

Rotate the knob in the arrow direction to align the icon "  " with "  " to turn on the low beam headlights.



Rotate the knob in the arrow direction to align the icon "  " with "  " to turn on the low beam headlights and the high beam

## 7. CONTROL AND PARTS FUNCTIONS

headlights.



### WARNING

Use caution and drive at reduced speeds in conditions of reduced visibility such as fog, rain and darkness.

#### 3. Horn Switch

Press the icon button to sound the horn. Release the icon button to turn off the horn.

#### 4. Main Switch

Functions of the respective switch positions are as follows:



: All electrical circuits are supplied with power.



: All electrical circuits are switched off. The key can be removed in this position.



: The electric starter is engaged by turning and holding the key in this position. Release the key when the engine starts.



### CAUTION

Do not operate the electric starter continuously for more than 5 seconds, or starter damage could occur. Wait at least 5 seconds between each operation of the electric starter to let it cool.

Do not turn the key to the “” position with the engine running, or damage to the electric starter can result.

#### 5. Rear Diff Lock Switch

When in 2WD, the switch can change rear diff lock or rear diff unlocked. When in 4WD, the switch can not work, the vehicle will stay rear diff lock.

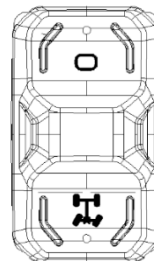

## **7. CONTROL AND PARTS FUNCTIONS**

### 6. Winch Switch (Option)

- OUT** With the vehicle powered on and the engine started, long-press position 'OUT'. The winch cable will extend.
- IN** With the vehicle powered on and the engine started, long-press position 'IN'. The winch cable will retract.



### **WARNING**

Operating the winch improperly will cause accidents resulting in serious injury or death. Please refer to “Installation Instructions, Operator's Manual and Replacement Parts List for the 2000&2500 3000&3500&4000LB ATV Winch” for proper winch operation and cautions.



### **CAUTION**

To preserve battery power, always operate the winch with the engine running.

### 7. Hazard Switch (Option)

When the hazard switch is in use, the front and rear turning lights will flash. At the same time, the hazard switch indicator on the instrument will light up.

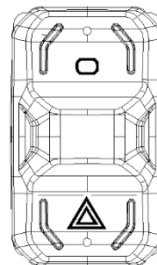

### 8.9. USB Outlet

The USB power socket 2 includes one TYPE-C connector and one TYPE-A connector for charging:

## **7. CONTROL AND PARTS FUNCTIONS**

---

- 1.Nominal Voltage: DC 12V
- 2.Working Voltage: DC 10 ~ 24V
- 3.Output Voltage Range: DC 3 ~ 12V (According to quickcharge strategy that adjusts the range)
- 4.Maximum Output Power: 18W+18W (5V@3A, 9V@2A, 12V@1.5A)
- 5.Output power: 5V@3A if the socket does not recognize a quick-charge strategy.



### **CAUTION**

To ensure optimal results, always use the original USB cable to connect. When you are done using an accessory, unplug it, and cover the USB Outlet with the cap.

Be careful not to flood this accessory socket when washing your UTV.

## 7. CONTROL AND PARTS FUNCTIONS

### TFT INSTRUMENT

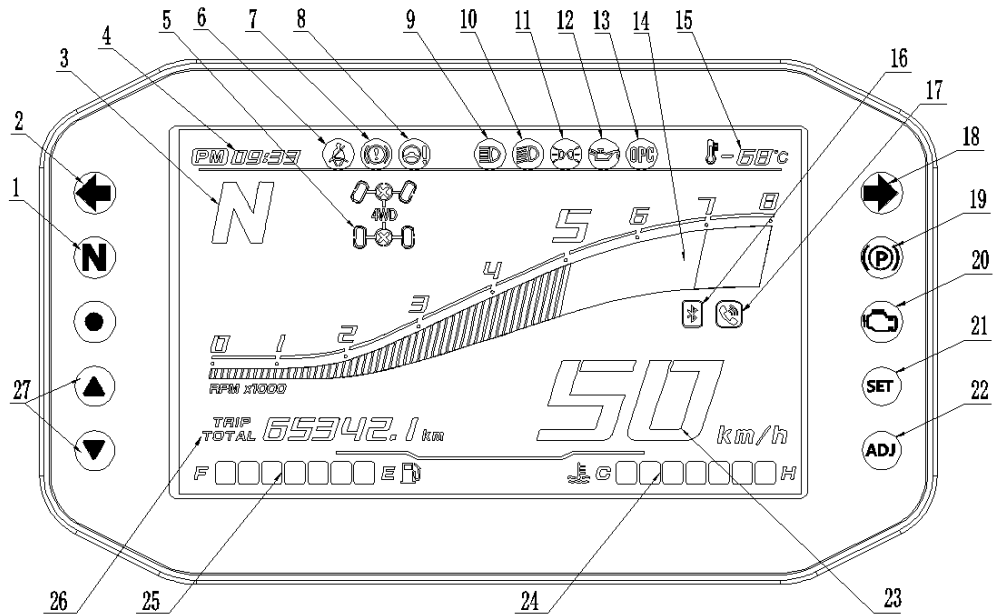

1	Neutral indicator(green)	15	Ambient Temperature
2	Turn left indicator light(green)	16	Bluetooth indicator
3	Gear position indicator	17	Telephone call indicator
4	Clock	18	Turn right indicator light(green)
5	Drive mode	19	Parking brake indicator(red)
6	Safety Belt Lamp	20	MIL indicator(yellow)

## 7. CONTROL AND PARTS FUNCTIONS

7	Brake fault warning indicator(red)	21	SET - mode select button
8	EPS fault indicator(red)(Option)	22	ADJ - mode adjust button
9	High beam indicator(blue)	23	Speedometer
10	Low beam indicator(green)	24	Coolant temperature gauge
11	Position light indicator(green)	25	Fuel level(yellow)
12	Oil pressure indicator(red)	26	ODO/trip
13	OPC(red)( <b>OPTION</b> )	27	up and down buttons
14	Engine RPM meter		



### WARNING

When turn on the key but not start the engine, the MIL Indicator will on. After the engine starting, the MIL Indicator will turn off. If the MIL Indicator lighting or flashing while the engine working, please consult an authorized UTV dealer and repair it immediately to avoid the vehicle damaged.

#### 1.Neutral indicator (green)

This indicator displays when the transmission is in neutral position.

#### 2.Turn left indicator light (green)

When switch turns to left turning light position, the left turning indicator will be on.

#### 3..Gear position indicator

Displays the current gear position:L,H,N,R,P.

#### 4.Clock

Displays the current time. This dashboard section can be adjusted by using the “ADJ” and “SET” buttons.

#### 5.Drive mode

Display the current drive mode, there are three modes, 2WD, 4WD ,4WD LOCK and 4WD REAR DIFF LOCK. If the mode is not engaged successfully, the indicator will flash or not display.

## **7. CONTROL AND PARTS FUNCTIONS**

### **6.Safety Belt Lamp**

When the vehicle is powered on, the safety belt lamp flashes for 8 seconds, reminding the driver to fasten their seat belt.

### **7.Brake fault warning indicator (red)**

This indicator displays when brake fluid level is very low. Add DOT4 brake fluid and contact your dealer.

Low brake fluid level may lead to air in the brake system, causing brake fault and lead to serious accident.

### **8.EPS fault indicator(red)(OPTION)**

The indicator will be on when a fault occurs in the Electronic Power Steering system. Please stop the vehicle and contact your dealer to inspect and eliminate the fault.Continuing to operate could lead to permanent EPS damage and increase the steering force.

### **9.High beam indicator (blue)**

This indicator illuminates when the headlight switch turns to high beam position.

### **10.Low beam indicator (green)**

This indicator illuminates when the headlight switch turns to low beam position.

### **11.Position light indicator (green)**

This indicator illuminates when the light switch turns to position light.

### **12.Oil pressure indicator (red)**

The oil pressure indicator is on when the oil pressure is very low. Please have your vehicle stopped safely at once when the indicator is on, and contact your dealer to eliminate the fault.

### **13.OPC(red)(OPTION)**

When operator leaves the driving position with vehicle is stationary and the park brake or park lock not applied. OPC will display and sound. The OPC will be not display and not sound when the operator is detected to be present again in the driving position within this time period or when the park brake or park lock is applied within this time period.

## **7. CONTROL AND PARTS FUNCTIONS**

---

### **14.Engine RPM meter**

Indicate the engine current RPM.

### **15.Ambient Temperature**

Display the ambient temperature around the vehicle.

### **16.Bluetooth indicator**

This vehicle is equipped with bluetooth function for display calls from a mobile phone .The bluetooth icon will not light when it is not paired and connected to a phone. It will remains on after pairing successfully and staying connected. The telephone icon will flash when there is an incoming call, it remains on while the call is connected. and it turns off when the call is disconnected.

To pair, open the bluetooth function in the mobile phone, turn the vehicle main key switch to "ON", then connect to the vehicle's bluetooth feature using the phone.



### **WARNING**

Do not operate the vehicle while using bluetooth. Always stop the vehicle before answering a call. Distracted driving can result in an accident causing serious injury or death.

### **17.Telephone call indicator**

After bluetooth pairing successfully, this indicator flashes when there is an incoming call.

### **18.Turn right indicator light (green)**

When switch turns to right turning light position, the right turning indicator will be on.

### **19.Parking brake indicator (red)**

This indicator displays when parking brake function is activated.

### **20.MIL indicator (yellow)**

This indicator displays when a fault occurs in the Electronic Fuel Injection system. Please stop the vehicle and contact your dealer to eliminate the fault, or it may result in serious engine damage.

## **7. CONTROL AND PARTS FUNCTIONS**

---



### **WARNING**

When open the key but not start the engine, the MIL Indicator will on. After the engine starting the MIL Indicator will turn off. If the following two conditions are found please consult an authorized ATV dealer and repair it immediately to avoid the vehicle damaged.

1. the MIL Indicator lighting or flashing while the engine working
2. the MIL Indicator not lighting while open the key and not start the engine.

#### **21.SET - mode select button**

Use together with "ADJ" key to adjust functions on the dashboard. Long press and hold the "SET" key to enter the secondary system interface settings; Short press the "SET" key to switch between "TATAL", "TRIP", engine working time, and voltage.

#### **22.ADJ - mode adjust button**

Use this key together with "SET" key to set the information on dashboard. Press and hold the "ADJ" key: In the "TRIP" state, the subtotal will be reset to zero; Short press the "ADJ" key to switch between "km", "km/h", "mile", and "mph".

#### **23.Speedometer**

Displays the current vehicle speed. Speedometer section can be toggled to display the vehicle speed in Kilometers per hour (km/h) or Miles Per Hour(mph).

#### **24.Coolant temperature gauge**

Both over-low and over-high of the coolant temperature are abnormal. Idle the vehicle to warm the engine. when it's too cold, and park the vehicle when it's too hot to prevent the coolant from boiling. Keep the coolant temperature in a normal range.

#### **25.Fuel level (yellow)**

Displays the fuel level in the fuel tank.

#### **26.ODO/trip**

Default display is total mileage the vehicle has traveled. Press "SET"

## **7. CONTROL AND PARTS FUNCTIONS**

button to toggle to TRIP meter, engine hour, and battery voltage. The rider information center will loop display the EFI fault code, ABS fault code or EPS fault code if the vehicle have.

### **27.Up and down buttons**

Long press and hold the SET key to enter the secondary system interface settings; Switch the display system version, tire pressure unit, clock setting and time 12/24 standard by using the up and down buttons.

### **ACCELERATOR PEDAL**



#### **WARNING**

Before starting the engine, check the accelerator pedal to be sure it is operating smoothly.

Make sure the accelerator pedal fully returns to the idle position as soon as it is released.

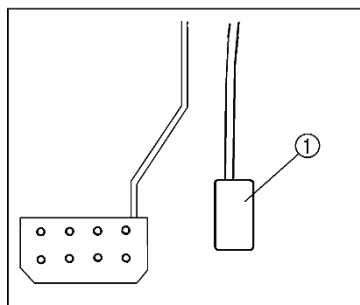

1. Accelerator pedal

Press the accelerator pedal down to increase engine speed. Spring pressure returns the pedal to the rest position when released. Always check that the accelerator pedal returns normally before starting the engine.



#### **WARNING**

##### **POTENTIAL HAZARD**

Malfunction of the accelerator pedal.

##### **WHAT CAN HAPPEN**

The accelerator pedal could be hard to operate, making it difficult to speed up or slow down when you need to. This could cause an accident.

##### **HOW TO AVOID THE HAZARD**

## **7. CONTROL AND PARTS FUNCTIONS**

Check the operation of the accelerator pedal before you start the engine. If it does not work smoothly, check for the cause. Correct the problem before operating the vehicle. Consult the authorized dealer if you can't find or solve the problem yourself.

---

### **BRAKE PEDAL**

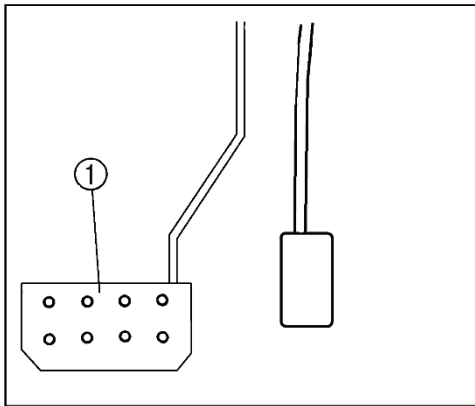

1.Brake pedal

Press the brake pedal to slow or stop the vehicle.



### **WARNING**

Never operate the UTV with a spongy feeling brake pedal. Operating the UTV with a spongy brake pedal can result in loss of braking. Loss of braking could cause an accident.

---

### **PARKING BRAKE LEVER**

## 7. CONTROL AND PARTS FUNCTIONS

The parking brake lever is located at the left side of the steering wheel. It will help hold the vehicle from moving while parked. To set the parking brake, pull the lever up completely. The parking indicator light will come on if the main switch is on. To release the parking brake, pull up on the lever, press the release button, and then push the lever all the way down. Be sure to fully release the parking brake before starting out. Failure to do so may result in poor performance and premature wearing of the parking brake and V-belt.

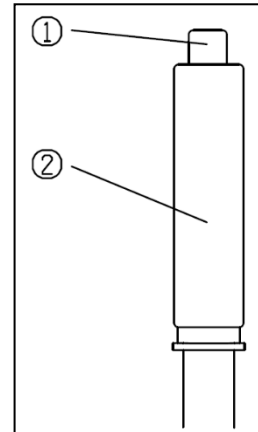

1. Release button
2. Parking brake lever

### AUTOMATIC TRANSMISSION GEAR SELECTOR OPERATION

The transmission gear selector is located at the right side of the steering wheel. The transmission selector lever has four positions: reverse; neutral; high forward; and low forward

**NOTE:** To extend belt life, use low forward gear in heavy pulling situations and in situations where you are operating below 7mph(11km/h) for extended periods of time.

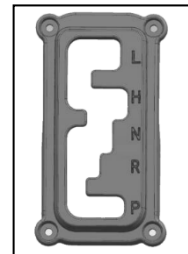

### CAUTION

To change gears, stop the vehicle and with the engine idling, move the lever to the desired gear. Shifting gears with the engine speed above idle or while the vehicle is moving could cause transmission damage. Always place the transmission in gear with the parking brake locked whenever the vehicle is left unattended.

Maintaining shift linkage adjustment is important to assure proper transmission function. Should you experience any shifting problem see your dealer.

## **7. CONTROL AND PARTS FUNCTIONS**

---



### **WARNING**

#### **POTENTIAL HAZARD**

Engaging a lower gear when the engine speed is too high.

#### **WHAT CAN HAPPEN**

The wheels could stop rotating. This could cause loss of control, an accident and injury. It could also cause engine or drive train damage.

#### **HOW TO AVOID THE HAZARD**

Make certain the engine has sufficiently slowed before shifting to a lower gear.

---

### **FUEL TANK CAP**

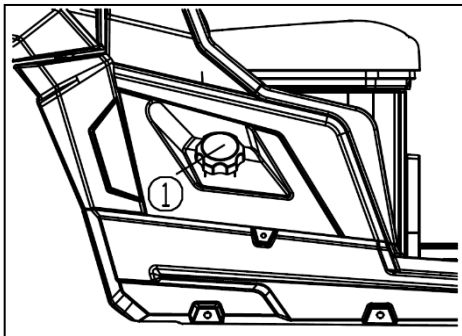

1. Fuel tank cap

Remove the fuel tank cap by turning it counterclockwise.

### **SEATS**

## **7. CONTROL AND PARTS FUNCTIONS**

---

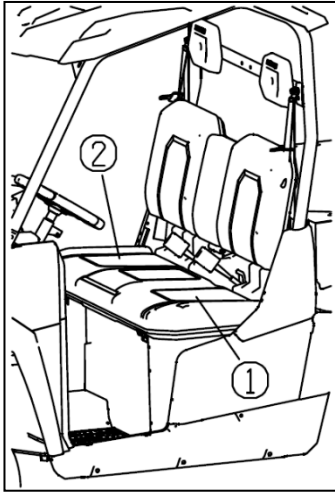

1. Drive seat
2. Passenger seat

To remove a seat, lift the rear of the seat, and then slide the seat up and backward.

To install a seat, push down on the seat at the front and insert the projections on the rear of the seat into the seat holders.



### **WARNING**

#### **POTENTIAL HAZARD**

A loose seat.

#### **WHAT CAN HAPPEN**

The operator could lose control or the operator or passenger could fall if the seat is loose during operation.

#### **HOW TO AVOID THE HAZARD**

Make sure the seat is securely latched.

---

### **SEAT BELTS**

## 7. CONTROL AND PARTS FUNCTIONS

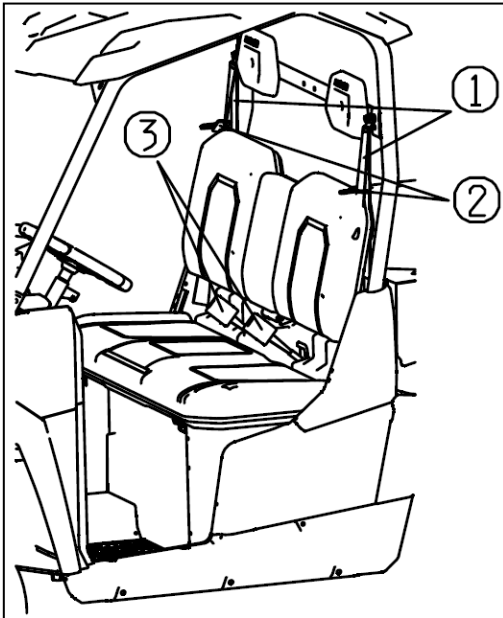

1. Seat belt (×2)

2. Latch plate (×2)

3. Buckle (×2)

This vehicle is equipped with three-point seat belts for both the operator and passenger. Always wear the seat belt while riding in the vehicle.

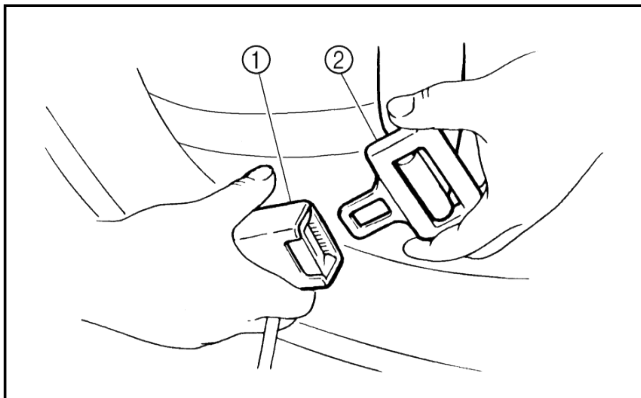

1. Buckle

2. Latch plate

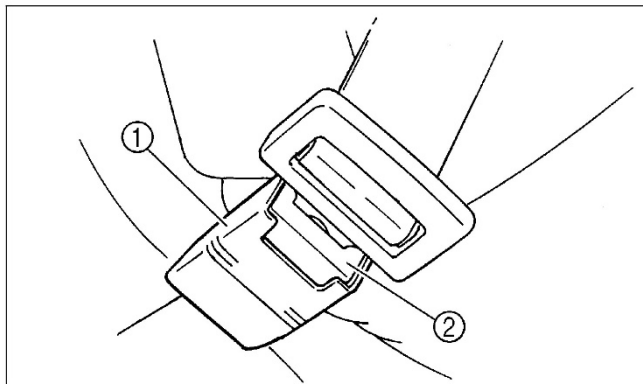

1. Buckle

2. Release button

**To Wear The Seat Belt Properly, do the following:**

## **7. CONTROL AND PARTS FUNCTIONS**

---

1. Hold the latch plate as you pull the belt across your lap and chest. Make sure the belt is not twisted and is not caught on any portion of the vehicle, your clothing, or any equipment you are carrying.
2. Push the latch plate into the buckle until it clicks. Pull up on the latch plate to make sure it is secure.
3. Put the lap portion of the belt low on your hips. Push down on the buckle end of the belt as you pull up on the shoulder part so the belt is snug across your hips.
4. Position the shoulder belt over your shoulder and across your chest. The shoulder belt should fit against your chest. If it is loose, pull the belt out all the way and then let it retract.

**To Release The Buckle**, firmly press the release button.



### **WARNING**

#### **POTENTIAL HAZARD**

Not wearing the seat belt.

Wearing the seat belt improperly.

#### **WHAT CAN HAPPEN**

There is increased risk of being killed or seriously injured in an accident.

#### **HOW TO AVOID THE HAZARD**

Always wear your seat belt when riding in the vehicle.

Be sure the seat belt is close-fitting across your hips and chest and is latched securely.

---



### **CAUTION**

To protect from damage, do not put metal products, like tools or sharply edged products directly in the glove compartment. If they must be stored, wrap them in appropriate cushion material.

---

## 7. CONTROL AND PARTS FUNCTIONS

### CARGO BED

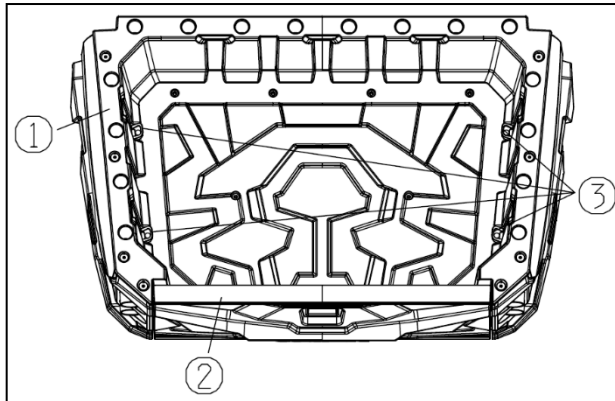

- 1.Cargo bed
- 2.Tailgate
- 3.Cargo hook (×4)

### Opening And Closing The Tailgate

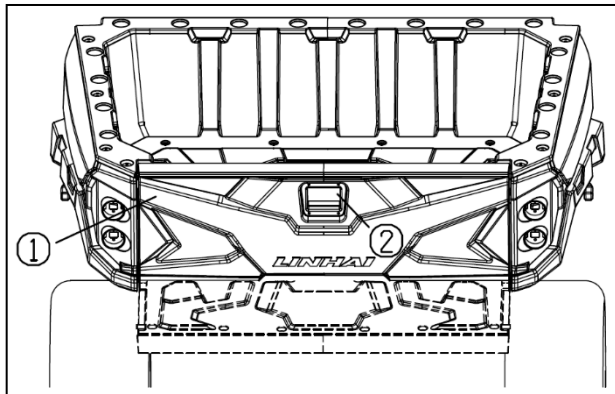

- 1.Tailgate
2. handle

To open  
Pull the handle, and then  
lower the tailgate.

To close  
Place the tailgate in the original position, and be sure that it is locked  
into place.

### Lifting And Lowering The Cargo Bed

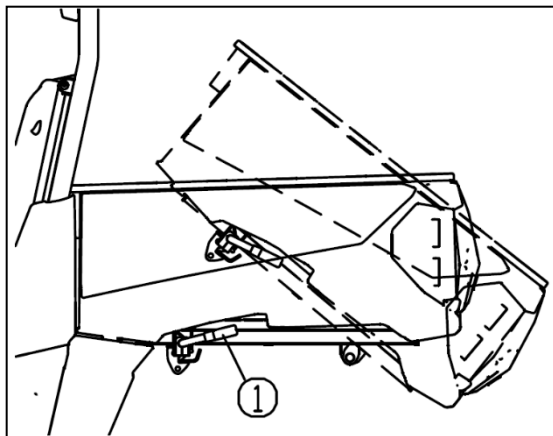

- 1.Cargo bed release lever

To lift  
Push down the cargo bed  
release lever on the left or  
right side of the vehicle, and  
then slowly lift up the cargo  
bed until it stops.

## **7. CONTROL AND PARTS FUNCTIONS**

---

To lower

Lower the cargo bed slowly to its original position and be sure that it is locked into place.



### **WARNING**

#### **POTENTIAL HAZARD**

Pinch points.

#### **WHAT CAN HAPPEN**

You or someone else could be pinched between the cargo bed and the frame when the bed is being lowered.

#### **HOW TO AVOID THE HAZARD**

Before closing the bed, be sure others are standing away from the vehicle. Keep hands and fingers away from the pinch points between the bed and the frame.

---

#### **Load Limit**

#### **CARGO BED**

Maximum load limit: 150 kg (330 lb)



### **WARNING**

#### **POTENTIAL HAZARD**

Overloading the cargo bed

#### **WHAT CAN HAPPEN**

Could cause changes in vehicle handling which could lead to an accident.

#### **HOW TO AVOID THE HAZARD**

Never exceed the stated maximum load limit for this cargo bed. Cargo should be properly distributed and securely attached. Reduce speed when carrying cargo. Allow greater distance for braking.



### **WARNING**

## **7. CONTROL AND PARTS FUNCTIONS**

---

### **POTENTIAL HAZARD**

Carrying a passenger/ passengers in the cargo bed

### **WHAT CAN HAPPEN**

The passenger(s) could fall, be thrown out, or be struck by objects in the cargo bed.

### **HOW TO AVOID THE HAZARD**

Never carry a passenger/ passengers in the cargo bed. This cargo bed is designed to carry cargo only.

---

### **TRAILER HITCH BRACKET**

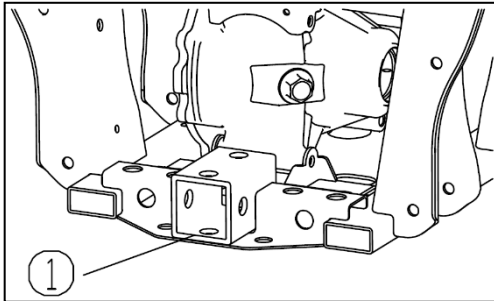

1.Trailer hitch bracket

This vehicle is equipped with a receiver bracket for a standard trailer hitch.

### **HOOD**

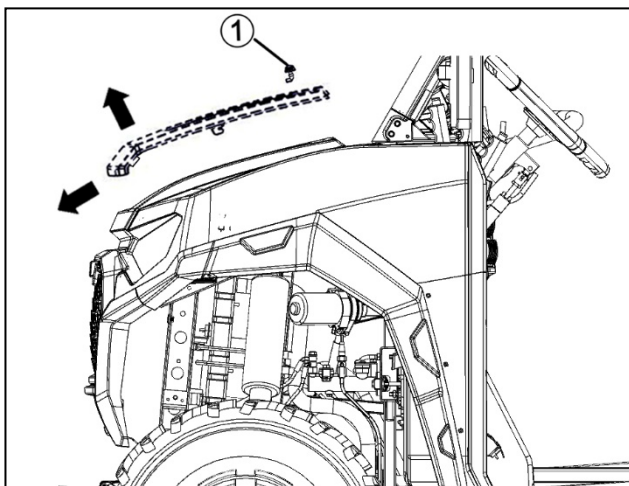

1.latch (x2)

### **To Open**

Unhook the hood latches, pull down the hood and then take it out.

## 7. CONTROL AND PARTS FUNCTIONS

### To Close

Put the hood in place, push up it and then lock the latch.



### WARNING

If the hood latches are hooked improperly, or the latches and their attachments can not work properly, the front hood can come off during operation, striking the driver or passenger and causing serious personal injury.

## ENGINE COOLING SYSTEM

### Coolant Level

The recovery bottle, located the left of the frame, must be maintained between the minimum and levels indicated on the recovery bottle.

The engine coolant level is controlled or maintained by the recovery system. The recovery system components are the recovery bottle, radiator filler neck, radiator pressure cap and connecting hose.

As coolant operating temperature increases, the expanding (heated) excess coolant is forced out of the radiator past the pressure cap and into the recovery bottle. As engine coolant temperature decreases, the contracting (cooled) coolant is drawn back up from the tank past the pressure cap and into the radiator.

**NOTE:** Some coolant level drop on new machines is normal as the system is purging itself of trapped air. Observe coolant levels and maintain as recommended by adding coolant to the recovery bottle. We recommends the use of high quality aluminum compatible anti-freeze coolant.

**NOTE:** Always follow the manufacturer's mixing recommendations for the freeze protection required in your area.

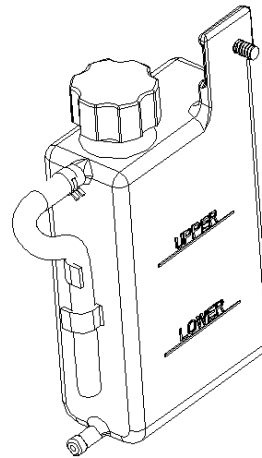

### WARNING

## **7. CONTROL AND PARTS FUNCTIONS**

Never remove the pressure cap when the engine is warm or hot. Escaping steam can cause severe burns. The engine must be cool before removing the pressure cap.

---

### **Radiator Coolant Level Inspection**

**NOTE:** This procedure is only required if the cooling system has been drained for maintenance and/or repair. However, if the recovery bottle has run dry, the level in the radiator should be inspected and coolant added if necessary.

**NOTE:** Use of a non-standard pressure cap will not allow the recovery system to function properly. If the cap should need replacement contact your dealer for the correct replacement part. To insure that the coolant maintains its ability to protect the engine, it is recommended that the system be completely drain every two years and a fresh antifreeze be added.

Using a funnel, slowly add coolant as necessary through the radiator filler neck.

### **FUEL AND OIL SYSTEM**



#### **WARNING**

Gasoline is highly flammable and explosive under certain conditions.

- Always exercise extreme caution whenever handling gasoline.
  - Always refuel with the engine stopped and outdoors or in a well ventilated area.
  - Do not smoke or allow open flames or sparks in or near the area where refueling is performed or where gasoline is stored.
  - Do not over fill the tank. Do not fill the tank neck.
  - If you get gasoline on your skin or clothing, immediately wash it off with soap and water and change clothing.
  - Never start the engine or let it run in an enclosed area. Gasoline powered engine exhaust fumes are poisonous and can cause loss of consciousness and death in a short time.
-

## 7. CONTROL AND PARTS FUNCTIONS



### WARNING

The engine exhaust from this product contains chemicals known, in certain quantities, to cause cancer, birth defects or other reproductive harm.

### Recommended Fuel: Unleaded Gasoline Only

Fuel tank capacity: 26.0 L (5.72 Imp gal, 6.87 US gal)



### CAUTION

Use only unleaded gasoline. The use of leaded gasoline will cause severe damage to internal engine parts, such as the valves and piston rings, as well as to the exhaust system.

Use 87 octane or higher gasoline.

### Fuel filter

The filter should be replaced by your dealer every 100 hours of operation or annually. Do not attempt to clean the fuel filter.

### Oil System

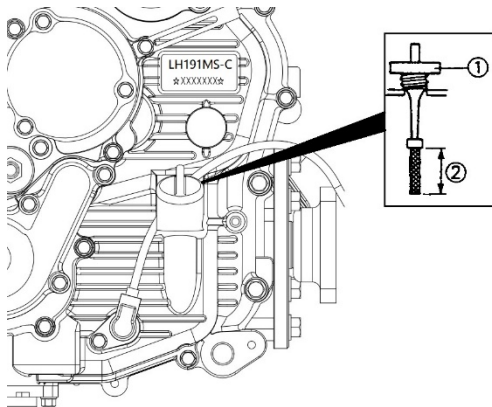

#### 1. Dipstick

The oil tank is located on the right side of the vehicle.

To check the oil:

1. Set machine on a level surface.
2. Start the engine and let it idle for 20-30 seconds.
3. Stop the engine, remove dipstick (1) and wipe dry with a clean cloth.
4. Put dipstick into the oil tank (don't screw in it), remove it and read the oil level.
5. Remove dipstick and check to see that the oil level is between the full and add marks(2). Add oil as indicated by the level on the dipstick. Do not overfill.

## **7. CONTROL AND PARTS FUNCTIONS**

---



### **CAUTION**

Use only SAE 15W/40, SJ OIL. Never substitute or mix oil brands. Serious engine damage and voiding of warranty can result.

---

## 8. STARTING THE ENGINE

---

### Procedure for Starting a Cold Engine



#### **WARNING**

Never run an engine in an enclosed area. Carbon monoxide exhaust gas is poisonous and can cause severe injury or death. Always start engines outdoors.



#### **WARNING**

#### **POTENTIAL HAZARD**

Freezing control cables in cold weather.

#### **WHAT CAN HAPPEN**

You could be unable to control the vehicle, which could lead to an accident or collision.

#### **HOW TO AVOID THE HAZARD**

When riding in cold weather, always make sure all control cables work smoothly before you begin riding.



#### **CAUTION**

You must allow your vehicle adequate warm up time before operating or engine damage could result.

---

1. Apply the brake.
2. Shift the drive select lever into the neutral position or parking position.

**NOTE:** When the drive select lever is in the neutral position, the Gear Position Indicator display “N” and the Neutral Indicator is illuminated. When the drive select lever is in the parking position, the Gear Position Indicator display “P”. If the Gear Position Indicator does not display “N” and the Neutral Indicator isn’t illuminated or does not display “P”, ask a dealer to inspect the electric circuit.

Only in the neutral position or in the parking position and applying the brake, the engine can be started.

## 8. STARTING THE ENGINE

---

3. With your foot off the accelerator pedal, start the engine by turning the key to “”.

**NOTE:** If the engine fails to start, release the key, and then try starting again. Wait a few seconds before the next attempt. Each cranking should be as short as possible to preserve battery energy. Do not crank the engine more than 5 seconds on each attempt.

Immediately after the engine starts, Continue warming up the engine until it runs smoothly.

### Jump-starting

Jump-starting the vehicle should be avoided. The battery should be removed and charged instead. However, if the vehicle must be jumps started, proceed as follows.

1. Turn the key to “”.
2. Open the front hood.
3. Using a charged 12 V battery, connect the positive lead of the jumper cable to the positive terminal of the battery in the vehicle and the other end of the positive lead to the positive terminal of the charged battery.

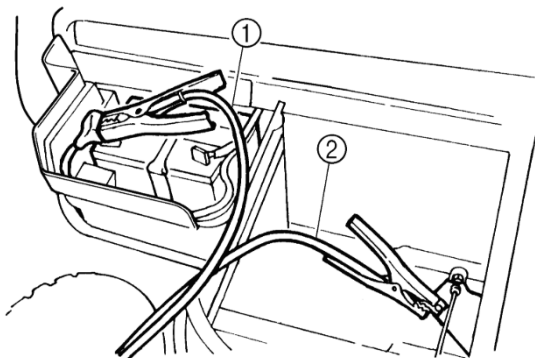

1. Jumper cable positive lead
2. Jumper cable negative lead

4. Connect the negative lead of the jumper cable to the negative terminal of the charged battery and the other end of the negative lead

## 8. STARTING THE ENGINE

---

to an unpainted metal surface of the vehicle.

5. Start the engine.

6. After the engine starts, disconnect the negative lead of the jumper cable from the vehicle and charged battery, and then disconnect the positive lead of the jumper cable from the charged battery and the battery in the vehicle.

7. Close the hood.



### **WARNING**

If the hood latches are hooked improperly, or the latches and their attachments can not work properly, the front hood can come off during operation, striking the driver or passenger and causing serious personal injury.

---

## 9. VEHICLE BREAK-IN PERIOD

---

The break-in period for your new UTV is defined as the first 50 hours of operation. No single action on your part is as important as a proper break in period. Careful treatment of new engine will result in more efficient performance and longer life for the engine. Perform the following procedures carefully.



### CAUTION

Do not operate at full throttle or high speeds for extended periods during the break-in period. Excessive heat can build up and cause damage to close fitted engine parts.

---

1. Fill fuel tank.
2. Check oil reservoir level indicated on dipstick. Add oil if necessary.
3. Drive slowly at first. Select an area which is open and will give you room to familiarize yourself with vehicle operation and handling.
4. Do not operate at sustained idle.
5. Perform regular checks on fluid levels, controls and all important areas on the vehicle as outlined earlier on the daily pre-ride inspection checklist found in "4.daily pre-ride inspection".
6. Don't pull loads.
7. Break in oil and filter. Change at 20 hours or 500 miles/800km.

## 10. RIDING GEAR

---

### **SAFE RIDING GEAR**

Always wear clothing suitable to the type of riding you are doing. UTV riding requires special protective clothing which will make you feel more comfortable and reduce chances of injury.

#### **1. Helmet**

Your helmet is the most important piece of protective gear for safe riding. A helmet can prevent a severe head injury.

Select an approved off-road motorcycle type helmet that fits properly.

#### **2. Eye Protection**

A pair of goggles or helmet face shield can offer the best protection for your eyes.

#### **3. Gloves (off-road style)**

The gloves can prevent the operator's and/or passenger's hands being wounded by something sharp during operation.

#### **4. Boots**

A pair of strong over the calf type boots with heels, such as motocross boots.

#### **5. Clothing**

To protect your body, long sleeves and pants should always be worn. Riding pants with kneepads, a jersey and shoulder pads provide the best protection.

## 10. RIDING GEAR

---



### **WARNING**

#### **POTENTIAL HAZARD**

Operating this vehicle without wearing an approved motorcycle helmet, eye protection and protective clothing.

#### **WHAT CAN HAPPEN**

Operating this vehicle without an approved motorcycle helmet increases your chances of a severe head injury or death in the event of an accident.

Operating this vehicle without eye protection can result in an accident and increases your chances of a severe injury in the event of an accident.

#### **HOW TO AVOID THE HAZARD**

Always wear an approved motorcycle helmet that fits properly. You should also wear: eye protection (goggles or face shield), gloves, boots, long-sleeved shirt or jacket long pants.

---

## 11. CARRYING LOADS

---

### CARRYING LOADS

Cargo or a trailer can change the stability and handling of a vehicle.

You must use common sense and good judgment when carrying cargo or towing a trailer. Keep the following points in mind:

- Never exceed the weight limits shown. An overloaded vehicle can be unstable.

<b>MAXIMUM LOADING LIMIT</b>	
○○○○○○○○	Cargo bed: 150 kg (330 lb)
	Trailer hitch:
	Pulling load (total weight of trailer and cargo): 490 kgf (1080 lbf)
	Tongue weight (vertical weight on trailer hitch point): 10 kgf (22 lbf)

- Choose a trailer hitch drawbar designed for use with a 5 cm (2 in) receiver.
- Do not exceed the maximum tongue weight. You can measure tongue weight with a bathroom scale. Put the tongue of the loaded trailer on the scale with the tongue at hitch height. Adjust the load in the trailer, if necessary, to reduce the weight on hitch. If you are carrying cargo and towing a trailer, include the tongue weight in the maximum vehicle load limit.
- Load cargo in the cargo bed as close to the center of the vehicle as possible and tie it down using the cargo hooks equipped on the cargo bed.
- Tie down cargo securely in the trailer. Make sure cargo in the trailer cannot move around. A shifting load can cause an accident.
- Make sure the load does not interfere with controls or your ability to

## 11. CARRYING LOADS

---

see where you are going.

- Drive more slowly than you would without a load. The more weight you carry, the slower you should go. Although conditions vary, it is good practice not to exceed low range whenever you are carrying heavier loads or when towing a trailer.
- Allow more braking distance. A heavier vehicle takes longer distance to stop.
- Avoid making sharp turns unless at very slow speeds.
- Avoid hills and rough terrain. Choose terrain carefully. Added weight affects the stability and handling of the vehicle.

---

### **Use A Safety Chain**

- A safety chain will help control drawn machinery should it separate from the tractor drawbar.
- Use a chain with the strength rating equal to or greater than the gross weight of the towed machinery.
- Attach the chain to the tractor drawbar support or other specified anchor location. Allow enough slack in the chain to permit turning.
- Never use a safety chain for towing.



## 11. CARRYING LOADS

---



### WARNING

#### POTENTIAL HAZARD

Overloading this vehicle or carrying or towing cargo improperly.

#### WHAT CAN HAPPEN

Could cause changes in vehicle handling which could lead to an accident.

#### HOW TO AVOID THE HAZARD

Never exceed the stated load capacity for this vehicle. Cargo should be properly distributed and securely attached. Reduce speed when carrying cargo or pulling a trailer. Allow a greater distance for braking.

---



### WARNING

#### POTENTIAL HAZARD

Carry a passenger / passengers in the cargo bed.

#### WHAT CAN HAPPEN

The passenger(s) could fall, be thrown out or be struck by objects in the cargo bed.

#### HOW TO AVOID THE HAZARD

Never carry a passenger in the cargo bed. The cargo bed is designed for carrying cargo only.

---

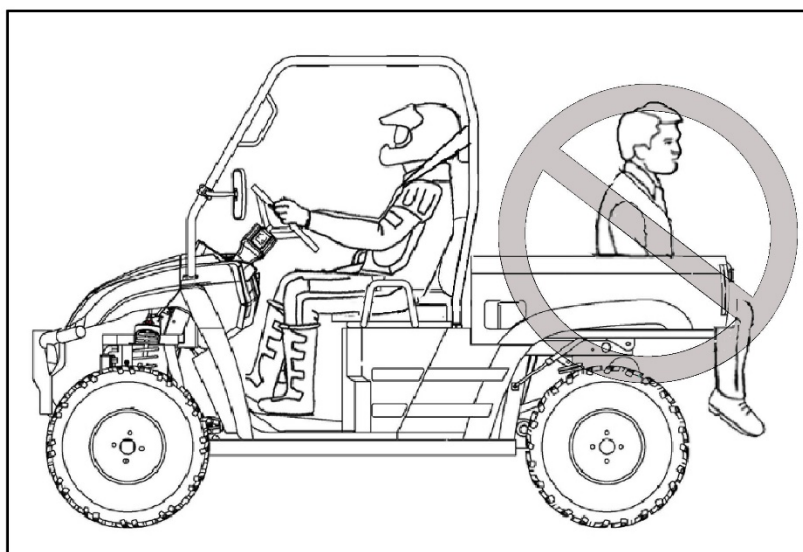

## 12. DRIVING

---

### **GETTING TO KNOW YOUR VEHICLE**

This off-highway utility vehicle will handle and maneuver differently from an ordinary passenger car or other vehicle. Before you begin to use your vehicle, be sure you have read this owner's manual completely and understand the operation of the controls. Pay particular attention to the safety information. Please also read all caution and warning labels on your vehicle. This vehicle is designed for the operator and one passenger. The driver and passenger must always wear a seat belt. when riding in the vehicle. Never carry passengers in the cargo bed.



### **WARNING**

#### **POTENTIAL HAZARD**

Not wearing the seat belt.

Wear a seat belt improperly.

#### **WHAT CAN HAPPEN**

There is an increased risk of serious injury or death in an accident.

#### **HOW TO AVOID THE HAZARD**

Always wear your seat belt when riding in the vehicle.

Be sure the seat belt is close-fitting across your hips and chest and is latched securely.



### **WARNING**

The engine rpm limiter works at 7000 rpm, this may cause excessive fuel to build in the exhaust, and ignited by the catalyst in the muffler, **MAY RESULT IN THE MUFFLERS OVERHEATING AND FIRE RISK.** Always reduce throttle when the engine reach top rpm, avoid the engine popping.



### **WARNING**

You must inspect you UTV each time before riding to ensure it is in proper working order. If proper inspection is not done, severe injury or death could result.

See“4.DAILY PRE-RIDE INSPECTION”for details.

## 12. DRIVING

---

### **LEARNING TO OPERATE YOUR VEHICLE**

You should become familiar with the performance characteristics of the vehicle in a large, flat area that is free of obstacles and other vehicles. Practice control of the accelerator pedal, brakes, steering, and drive select lever. Drive first at slow speed and become comfortable at that speed before gradually increasing your speed. Become familiar with the way the vehicle feels in low and high ranges, first in two-wheel drive (2WD) and then in four-wheel drive (4WD). Also practice driving in reverse. Take the time to learn basic operation before attempting more difficult maneuvers.

1. Set the parking brake, shift to neutral, and follow the instructions to start the engine.
  2. With the engine idling, shift the drive select lever into low or high. Then release the parking brake.
  3. Press the accelerator pedal slowly and smoothly. The centrifugal clutch will engage and you will start to accelerate. Avoid higher speeds until you are thoroughly familiar with the operation of your vehicle.
  4. When slowing down or stopping, take your foot off the accelerator pedal and smoothly press the brake pedal. Improper use of the brakes can cause the tires to lose traction, reducing control and increasing the possibility of an accident.
- 

### **MAKING TURNS**

It is possible for the vehicle to roll over or go out of control if you attempt sharp, high-speed turns. You should also be careful making sharp turns on rough terrain. Do not attempt to turn around or make abrupt maneuvers on slopes.

Position your hands on the steering wheel so that your thumbs and fingers do not wrap around the wheel. This is particularly important when driving in rough terrain. The front wheels will move right and left as they respond to the terrain, and this movement will be felt in the steering wheel. A sudden jolt could wrench the steering wheel around, and your thumbs or fingers could be injured if they are in the way of the

## 12. DRIVING

---

steering wheel spokes.

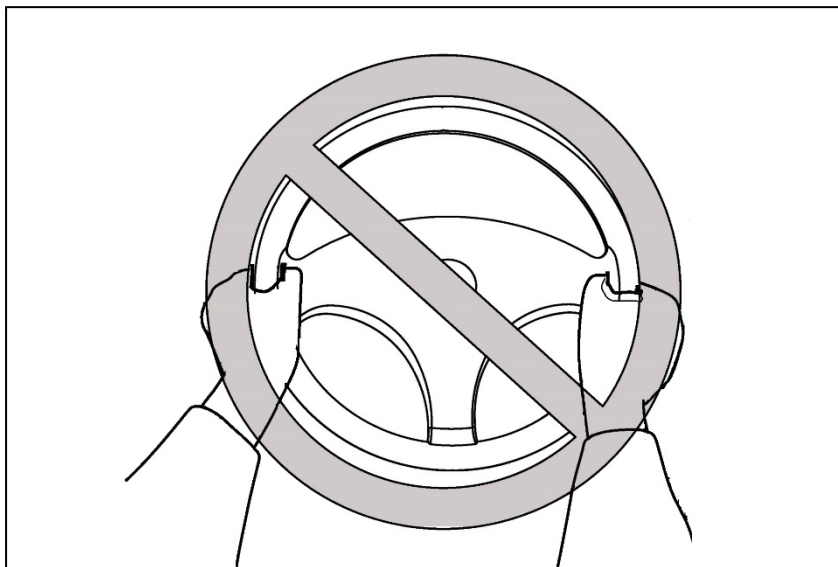

### **BRAKING**

Braking ability is affected by the type of terrain. In most cases, gradually application of the brakes is more effective than abrupt braking, particularly on loose surfaces like gravel. Always allow for greater braking distance on rough, loose, or slippery surfaces.

### **GOING UPHILL**

Do not attempt to climb hills until you have mastered basic maneuvers on flat ground. Use proper driving techniques to avoid overturns on hills and slopes. Drive straight up hills, and avoid crossing the side of a hill, which increases your chance of rollover. Practice first on gentle slopes before attempting steeper hills. Always check the terrain carefully before attempting any hill. Use common sense and remember that some hills are too steep for you to climb.

Choose carefully which hills you attempt to climb. Avoid hills with slippery surfaces or ones where you will not be able to see far enough ahead of you.



### **WARNING**

#### **POTENTIAL HAZARD**

Operating on excessively steep hills.

#### **WHAT CAN HAPPEN**

The vehicle can overturn more easily on extremely steep hills than on

## 12. DRIVING

---

level surfaces or small hills.

### HOW TO AVOID THE HAZARD

Never operate your vehicle on hills too steep for it or your abilities. Never operate vehicles on hills steeper than 20%. Do not drive across the face of a hill. Go straight up the hill. Practice on smaller hills before attempting large hills.

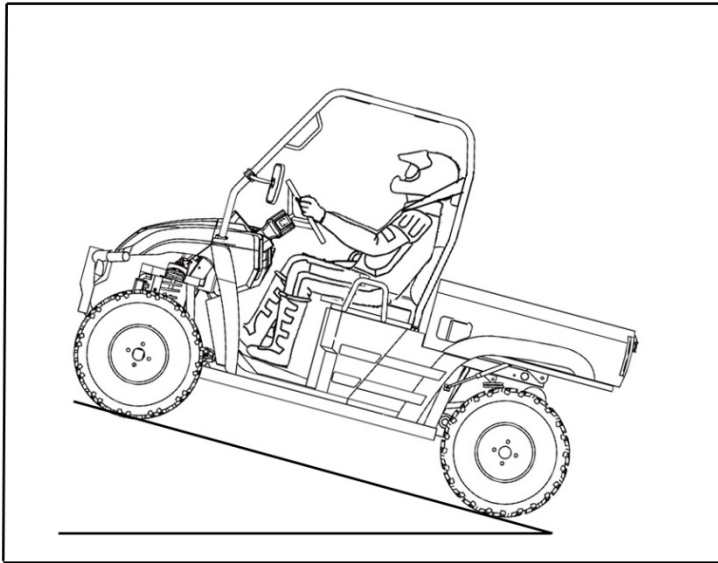

### 20% Maximum

Before climbing the hill, first be sure you are operating in low range 4WD (4WD mode). To climb a hill, you need traction, momentum, and steady throttle. Travel fast enough to keep your momentum going, but not so fast that you cannot react to changes in the terrain as you climb. Slow down when you reach the crest of the hill if you cannot clearly see what is on the other side – there could be another person, an obstacle, or a sharp drop off.

If you start to lose traction or momentum when climbing, and you decide you will be unable to continue, use the brakes to come to a stop. Do not attempt to turn the vehicle around. With your foot on the brake, look behind you and plan your descent. Release the brake and begin to coast down the hill, gently applying the brakes when necessary.

### GOING DOWNHILL

Check the terrain carefully before going down a hill. When possible, choose a path that lets you drive your vehicle straight downhill. Avoid sharp angles that could allow the vehicle to pitch or roll over. Carefully

## 12. DRIVING

---

choose your path and drive no faster than you will be able to react to obstacles that may appear.



### **WARNING**

#### **POTENTIAL HAZARD**

Going down a hill improperly.

#### **WHAT CAN HAPPEN**

Could cause loss of control or cause the vehicle to overturn.

#### **HOW TO AVOID THE HAZARD**

Always check the terrain carefully before you start down any hill. Never go down a hill at high speed. Avoid going down a hill at an angle that would cause the vehicle to lean sharply to one side.

Go straight down the hill where possible.

---

Before starting down hill, make sure the vehicle is in low-range 4WD (4WD mode). Go as slowly as possible. If you are starting to go too fast, apply the brakes gently. Avoid sudden application of the brakes, which could cause the vehicle to start sliding. If you are sliding or skidding, try to steer in the direction the vehicle is sliding to help you regain control. If you must turn on the hill to avoid an obstacle, do so slowly and carefully. If the vehicle starts to tip, gradually steer in the downhill direction if there are no obstacles in your path. As you regain proper balance, gradually steer again in the direction you want to go.



### **WARNING**

#### **POTENTIAL HAZARD**

Try to stop the tipping vehicle with your arm or leg.

#### **WHAT CAN HAPPEN**

You could be severely injured. You could suffer a crushed hand, arm, leg, or foot.

#### **HOW TO AVOID THE HAZARD**

You must keep your arms and legs inside the vehicle until it has stopped moving.

As with any off-road-capable vehicle, there is a risk of tip over or rollover under certain conditions. Uneven terrain or slopes which pitch the vehicle sideways, turning too fast or sharp, or a combination of conditions increase the risk of tip over.

## 12. DRIVING

---

If you are in a situation where the vehicle is tipping over, do not put your arm or/ and leg outside the vehicle, do not try to stop tipping with your arm or leg. You could be severely injured. You could suffer a crushed hand, arm, leg, or foot, if part of your body is caught underneath the vehicle.

---

### **CROSSING THROUGH SHALLOW WATER**

If you must cross shallow, slow moving water up to 200mm (8 in) depth, choose your path carefully to avoid sharp drop-offs, large rocks, or slippery surfaces that could cause the vehicle to overturn. Never operate through water deeper than 200mm (8 in) or fast flowing water. Wet brakes may have reduced effectiveness. After leaving the water, test your brakes. If necessary, apply the brakes several times to let friction dry out the linings.

**NOTE:** After running the vehicle in water, it is critical your machine is serviced as outlined in the maintenance chart see "16.maintenance". The following areas need special attention: engine oil, transmission oil, rear gearcase, and all grease fittings.



### **WARNING**

#### **POTENTIAL HAZARD**

Operating this vehicle through deep or fast-flowing water.

#### **WHAT CAN HAPPEN**

Loss of control, which could result in an accident including overturn, which could increase the risk of drowning.

#### **HOW TO AVOID THE HAZARD**

Never operate this vehicle in fast flowing water or in water deeper than 200 mm (8 in). Remember that wet brakes may have reduced stopping ability. Test your brakes after leaving water. If necessary, apply them several times to let friction dry out the linings.

---

### **RIDING OVER ROUGH TERRAIN**

Operating over rough terrain should be done with caution. Look for obstacles that could cause damage to the vehicle or could lead to a rollover or accident. Avoid jumping the vehicle as injury, loss of control, and damage to the vehicle could occur.

## 12. DRIVING

---



### **WARNING**

#### **POTENTIAL HAZARD**

Failure to use extra care when operating this vehicle on unfamiliar terrain.

#### **WHAT CAN HAPPEN**

You can come upon hidden rocks, bumps, or holes, without enough time to react. Could result in the vehicle overturning or going out of control.

#### **HOW TO AVOID THE HAZARD**

Go slowly and be extra careful when operating on unfamiliar terrain. Always be alert to changing terrain conditions when operating the vehicle.

---

#### **RIDING IN BRUSH OR WOODED AREAS**

When operating in areas with brush or trees, watch carefully on both sides and above the vehicle for obstacles such as branches that the vehicle might hit, causing an accident, or for brush that might enter the vehicle as you pass and strike the driver or passenger. Never hold onto the enclosure so your hand is outside the vehicle. Hold only onto the handgrip inside the enclosure.

#### **ENCOUNTERING OBSTACLES ON THE TRAIL**

If you cannot go around an obstacle such as a fallen tree trunk or a ditch, stop the vehicle where it is safe to do so. Set the parking brake and get out to inspect the area thoroughly. Look from your approach side and the exit side. If you believe you can continue safely, decide the path that will allow you to get over the obstacle at as close to a right angle as possible to minimize vehicle tipping. Go only fast enough to maintain your momentum but still give yourself plenty of time to react to changes in conditions. If there is any question about your ability to maneuver safely over the obstacle, you should turn around, if the ground is flat and you have the room, or back up until you find a less difficult path.



### **WARNING**

## 12. DRIVING

---

### POTENTIAL HAZARD

Improperly operating over obstacles

### WHAT CAN HAPPEN

Could cause loss of control or a collision. Could cause the vehicle to overturn.

### HOW TO AVOID THE HAZARD

Before operating in a new area, check for obstacles. Use extreme caution when operating over large obstacles, such as large rocks or fallen trees.

---

### PARKING

When parking, stop the engine and shift the drive select lever into the neutral position. Apply the parking brake to help prevent the vehicle from rolling.

#### Parking on a slope

1. Bring the vehicle to a stop by applying the brakes.
2. Stop the engine.
3. With the brakes applied, set the parking brake.



### WARNING

### POTENTIAL HAZARD

Parking on a hill or other incline.

### WHAT CAN HAPPEN

The vehicle could roll out of control, increasing the chance of an accident.

### HOW TO AVOID THE HAZARD

Avoid parking on hills or other inclines. If you must park on an incline, apply the parking brake, and block the front and rear wheels with rocks or other objects. Do not park the vehicle at all on hills that are so steep you could not walk up them easily.

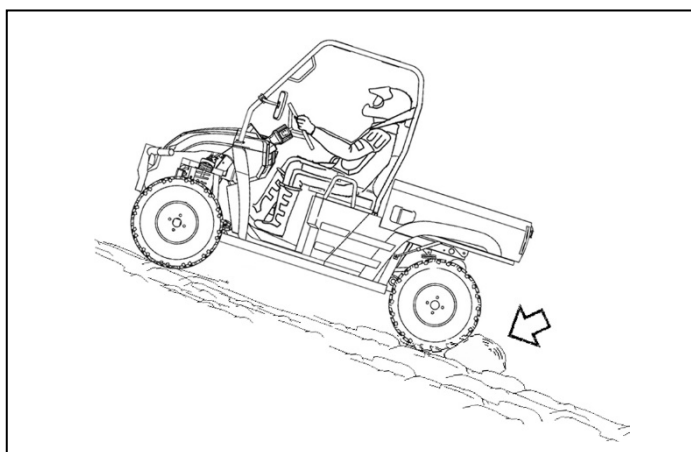

## 13. CVT SYSTEM

---



### WARNING

The CVT system rotates at high speeds, creating large amounts of force on clutch components. However, as the owner, you have the following responsibilities to make sure this system remains safe:

- Do not modify any component of the CVT system. Doing so may reduce its strength so that a failure may occur at high speeds. Any modification will cause the system to be out of balance, creating vibration and additional loads on components.
- Routine maintenance is the responsibility of the owner. Always follow recommended maintenance procedures. Contact your dealer!
- The CVT housing must be securely in place during operation.

**Failure to comply with this warning can result in severe injury or death.**

---

### **Low Range Use May Reduce CVT Operating Temperatures**

The basic operation of the CVT system is dependent on engine speed and vehicle torque requirements. As engine speed increased, the force exerted on the movable drive sheave by the fly-weights also increases. This, in turn, increases the amount of “pinch” applied to the drive belt. Similarly, if the engine speed decrease, the amount of centrifugal force decreases, reducing the amount of belt “pinch”.

## 13. CVT SYSTEM

---

### **CVT SYSTEM**

On UTV, the approximate gear ratio difference between high and low range is 1:1.87. This difference in gearing affects the operation of the CVT, especially at speeds less than 7 MPH, due to the system's dependence on engine speed.

By switching to low range while operating at low ground speeds, the air temperature in the clutch will be reduced. Reducing the temperature inside the clutch cover extends the life of the CVT components (belt, cover, etc.).

### **WHEN TO USE LOW RANGE**

The following lists provide a guideline for when to use low range rather than high.

#### **Low Range**

- Basic operation at speeds less than 7 MPH (11km/h)
- Heavy pulling
- Riding through rough terrain (swamps, mountains, etc.) at low ground speeds

#### **High Range:**

- Basic operation at speeds greater than 7 MPH (11km/h)
- High ground speeds

## 14. BATTERY



### WARNING

Whenever removing the battery, disconnect the negative (black) cable first. When reinstalling the battery, connect the negative (black) cable last. Otherwise, an explosive situation could result, causing serious injury or death.



### WARNING

Battery electrolyte is poisonous. It contains sulfuric acid. Serious burns can result from contact with skin, eyes or clothing. Antidote:

**External:** Flush with water.

**Internal:** Drink large quantities of water or milk. Follow with milk of magnesia, beaten egg, or vegetable oil. Call physician immediately.

**Eyes:** Flush with water for 15 minutes and get prompt medical attention. Batteries produce explosive gases. Keep sparks, flame, cigarettes, etc. away. Ventilate when charging or using in an enclosed space. Always shield eyes when working near batteries.

---

KEEP OUT OF REACH OF CHILDREN.

### Battery Removal

1. Disconnect hold down straps holding the electrical box and battery in position and remove battery cover.
2. Disconnect the black (negative) battery cable first.
3. Disconnect the red(positive) battery cable next.
4. Lift the battery out of the UTV, being careful not to tip it sideways and spill electrolyte.



### CAUTION

If electrolyte spills, immediately wash it off with a solution of one tablespoon baking soda and one cup water to prevent damage to the UTV.

---

### Battery Installation and Connections



### WARNING

## 14. BATTERY

---

To avoid the possibility of explosion, always connect battery cables in the order specified. Red (positive) cable first; black (negative) cable last. An exploding battery can cause serious injury or death.

---



### WARNING

Battery terminals and connections should be kept free of corrosion. If cleaning is necessary, remove the corrosion with a stiff wire brush. Wash with a solution of one tablespoon baking soda and one cup water. Rinse well with tap water and dry off with clean rags. Coat the terminals with dielectric grease or petroleum jelly. Be careful not to allow cleaning solution or tap water into the battery.

---

1. Set the battery in its holder.
2. First connect and tighten the red (positive) cable.
3. Second connect and tighten the black (negative) cable.
4. Reinstall battery cover and attach the hold down strap.
5. Verify that cables are properly routed.

#### NOTE:

- When your UTV is placed in storage for one month or more, the battery should be removed, charged to proper level, and stored in a cool dry place.
- Before reusing, take the battery to your dealer for testing and recharging.

Power plug leads may need to be bent down so that battery cover may be installed.

- When installing a new battery, make certain it is fully charged prior to its initial use. Using a new battery that has not been fully charged can damage the battery resulting in a shorter life of the battery. It can also hinder vehicle performance.



### CAUTION

Your UTV is equipped with a 18Ah Battery (or 30Ah Battery for EPS model). This may not be sufficient to provide power for optional equipment. When installing optional equipment please upgrade your battery as necessary. See your dealer for the proper battery.

---

## 15. EXHAUST SYSTEM

---

### SYSTEM REGULATION

#### TAMPERING WITH NOISE CONTROL SYSTEM PROHIBITED!

**CAUTION:** Exhaust system components are very hot during and after use of UTV.

- Do not touch exhaust system components. Serious burns can result.
- Be especially careful when traveling through tall grass. The potential for fire exists



### WARNING

The engine rpm limiter will work at 7000rpm, this may cause excessive fuel to build in the exhaust, and ignited by the catalyst in the muffler, **MAY RESULT IN THE MUFFLERS OVERHEATING AND FIRE RISK.**

Always reduce throttle when the engine reach top rpm, avoid the engine popping.

---



### WARNING

The engine exhaust from this product contains chemicals known, in certain quantities, to cause cancer, birth defects or other reproductive harm.

---

### Spark Arrestor

## 15. EXHAUST SYSTEM

---

The exhaust pipe must be periodically purged of accumulated carbon as follows:

1. Remove the 3 bolts and remove the arrester ① from the end of the muffler.
2. Use a non-synthetic brush to clean the arrester screen. A synthetic brush may melt if components are warm. If necessary, blow debris from the screen with compressed air.
3. Inspect the screen for wear and damage. Replace the arrester if damage is found.
4. Reinstall the arrester

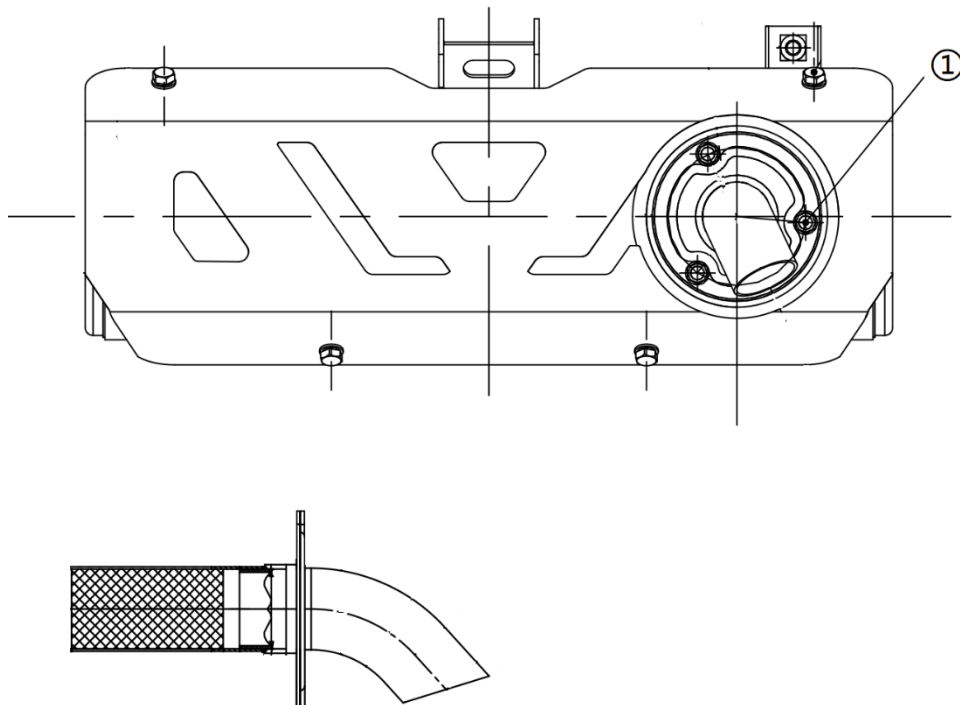

## 16. MAINTENANCE

### MAINTENANCE CHART KEY

SYMBOL	DESCRIPTION
I	Inspect
A	Adjust
R	Replace
C	Clean

The maintenance interval charts below is operated for normal use and a clean environment.

Maintenance period	Odometer (km)											Everyday check before riding
Items	300	1000	2000	3000	4000	5000	6000	7000	8000	9000	10000	
Lubricating oil		R		R			R			R		I
oil filter		R		R			R			R		
Air filter	Clean filter every 2000-3000 km.change it when necessary											
Spark plug	Initial 4000km and Clean every 3000~4000km change it when necessary											
Valve gap		A		A			A			A		
Fuel filter		C		C			C			R		
Brake function, brake pads		I	I	I	I	I	I	I	I	I	I	I
Brake fluid												
Fasteners(Excluding Engine Bolt)	T						T				T	
* When the mileage is over the highest on the table, please perform according to the period set on the table												
* Driving on dust place, it is recommended to clean it frequently.												



### WARNING

Vehicles subjected to heavy or severe use patterns must be maintenance with the maintenance interval charts below.

## 16. MAINTENANCE



### CAUTION

Due to the nature of the adjustments marked with a **D** on the following chart, it is recommended that service be performed by an authorized dealer.

- More often under severe use, such as dirty or wet conditions to purge water or dirt contamination from grease fittings and other critical components.

### PERIODIC MAINTENANCE SCHEDULE

Careful periodic maintenance will help keep your vehicle in the safest, most reliable condition. Inspection, adjustment and lubrication intervals of important components are explained in the following chart on the following pages.

#### NOTE:

Maintenance intervals are based upon average riding conditions and an average vehicle speed of approximately 16 km/ 10 miles per hour. However, keep in mind that if the vehicle isn't used for a long period of time, the month maintenance intervals should be followed. Vehicles subjected to severe use, such as operation in wet or dusty areas, should be inspected and serviced more frequently.

Inspect, clean, lubricate, adjust or replace parts as necessary.

#### NOTE:

Inspection may reveal the need for replacement parts. Always use genuine parts available from your dealer.

Service and adjustments are critical. If you are not familiar with safe service and adjustment procedures, have a qualified dealer perform these operations.

## 16. MAINTENANCE

	Item	Hours	When	Remarks
●	Brake System	Pre-ride	Pre-ride	Pre-ride inspection item
	Accelerator pedal	Pre-ride	Pre-ride	Inspect –adjust, lubricate, replace if necessary; pre-ride inspection item
	Fuel System	Pre-ride	Pre-ride	Check for leaks at tank cap, lines, fuel valve, filter, and carburetor.
●	Tires	Pre-ride	Pre-ride	Inspect daily, pre-ride inspection item
●	Front and Rear Wheels/ Hubs	Pre-ride	Pre-ride	Pre-ride inspection item
●	Steering	Pre-ride	Pre-ride	Inspect daily, lubricate
D	Wheels bearings	10 hrs	Monthly	Check for looseness/ damage. Replace if damaged.
	Frame nuts, bolts fasteners	Pre-ride	Pre-ride	Pre-ride inspection item
●	Air Filter-Pre-Cleaner	Daily	Daily	Inspect-Clean
	Coolant/Level Inspection	Daily	Daily	Replace engine coolant every one year
●	Air Box Sediment Tube	Daily	Daily	Drain deposits whenever visible
	Headlamp Inspection	Daily	Daily	Check operation daily; apply dielectric grease to connector when replaced
	Tail/ indicator lamp inspection	Daily	Daily	Check operation daily; apply dielectric grease to socket when replaced
●	Air Filter-Main Element	Weekly	Weekly	Inspect –Replace if necessary
	Battery	100 hrs	Yearly	Check/clean Terminal
D	Brake pad wear	10 hrs	Monthly	Inspect periodically
●	Rear Gear case Oil	100 hrs	Monthly	Check monthly and change annually
●	Front Gear case Oil	100 hrs	Monthly	Check monthly and change annually
	<b>Item</b>	<b>Hours</b>	<b>When</b>	<b>Remarks</b>

## 16. MAINTENANCE

	Engine Cylinder Head and Cylinder Base Fasteners	25 hrs	3 months	Inspect (re-torque required at first service only)
●	General Lubrication	50 hrs	3 months	Lubricate all fittings, pivots, cables, etc.
●	Engine Oil-Level/Change	30 hrs	3 months	Check Level Daily; Break in Service at 1 month. Change oil more often in cold weather use.
●	Oil Filter	50 hrs	6 months	Inspect-clean
	Engine breather hose	100 hrs	6 months	Inspect
D	Throttle Cable/ Accelerator pedal	20 hrs	monthly	Inspect –adjust, lubricate, replace if necessary; pre-ride inspection item
	Coolant strength	100 hrs	6 months	Inspect strength seasonally
	Shift linkage	50 hrs	6 months	Inspect, adjust
D	Drive belt	50 hrs	6 months	Inspect, replace if necessary
D	Steering system	50 hrs	6 months	Check operation and for looseness, worn, damage, binding feeling / Adjust, repair, Replace if necessary. Check toe alignment /Adjust if necessary.
D	Toe adjustment	As required	As required	Periodic inspection, adjust when parts are replaced
D	Front Axle (CV Joints, 4x4 model)	10 hrs	Monthly	Check for/ Axle boots/ looseness/ damage.
●	Rear Axle	50 hrs	6 months	Inspect bearings, Lube
●	Front Prop Shaft & Shaft Yoke	50 hrs	6 months	Check for looseness/ damage.
●	Rear Prop Shaft, Shaft Yoke & Boots	50 hrs	6 months	Check for/ boots/ looseness/ damage.

## 16. MAINTENANCE

●	Item	Hours	When	Remarks
●	Front Suspension	50 hrs	6 months	Inspect-lubricate, tighten fasteners
●	Rear Suspension	50 hrs	6 months	Inspect, tighten fasteners
	Spark Plug	100 hrs	12 months	Inspect-replace if necessary
D	Ignition Timing	100 hrs	12 months	Inspect and adjust as needed
D	Fuel System	50 hrs	6 months	Check for leaks at tank cap, lines, fuel valve, filter, and carburetor. Replace lines every one year
D	Fuel Filter	100 hrs	12 months	Replace annually
	Radiator	100 hrs	12 months	Inspect/clean external surface
	Cooling System hoses	50 hrs	6 months	Inspect/replace if necessary
	Spark arrestor	10 hrs	monthly	Clean out-replace if necessary
D	Clutches (drive and driven)	25 hrs	3 months	Inspect, clean
	Engine mounts	25 hrs	3 months	Inspect
D	Valve clearance	100 hrs	12 months	Inspect/adjust
D	Brake fluid	200 hrs	24 months	Change every two years
	Idle Speed	As required	As required	Adjust
	Headlight Aim	As required	As required	Adjust if necessary

# 16. MAINTENANCE

## LUBRICATION RECOMMENDATIONS

	Item	Lube Rec	Method	Frequency
●	1. Engine Oil	SAE 15W/40SJ	Add to proper level on dipstick	Check level daily
	2.Brake Fluid	DOT 3 Only	Maintain level Between fill lines. See "16. MAINTENANC/ Brakes"	As require; change every two years or 200 hours
	3.Rear Gear case oil	SAE GL-4 85W/90	See "16.MAI-NTENANCE/ Rear Gear Case Lubrication"	Change annually or at 100 hours
	4.Front Gear case oil (only for 4WD Model)	SAE GL-4 85W/90	See "16.MAI-NTENANCE/ Front Gear Case Lubrication"	Change annually or at 100 hours

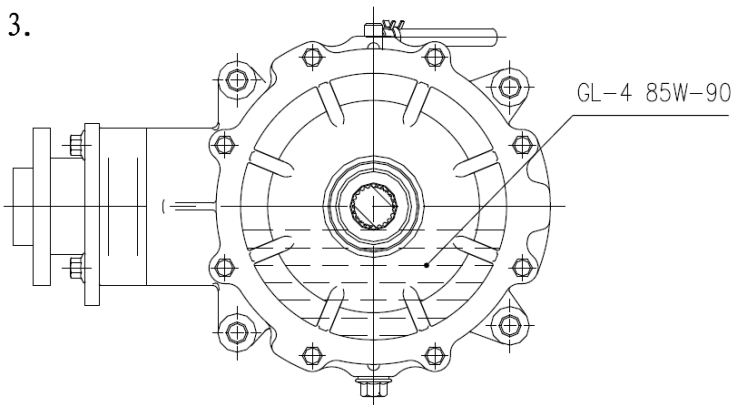
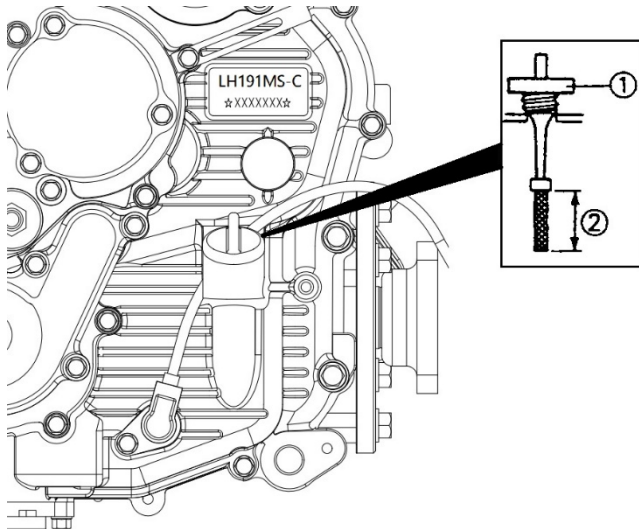

## 16. MAINTENANCE

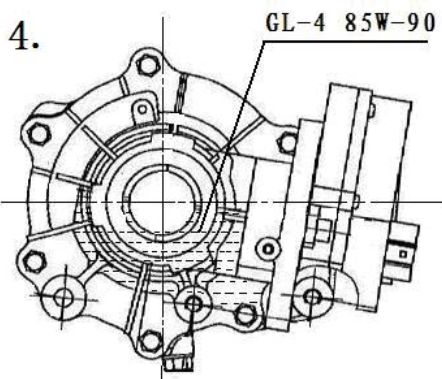

	<b>Item</b>	<b>Lube Rec</b>	<b>Method</b>	<b>Frequency</b>
●	5.Steering system	Grease	Lubricate the pivoting and sliding parts	Every 3 months or 50 hours
●	6.Tie rods	Grease	Grease	Semi-annually
●	7.Shift Linkages	Grease	Locate fittings and Grease	Semi-annually
●	8.Front Wheel bearings	Inspect	Inspect and replace bearings if necessary	Semi-annually
●	9.Ball joints	Grease	Inspect, Locate fittings and Grease, or replace it if necessary	Semi-annually
●	10.Prop Shaft & Shaft Yoke, Spline Joint	Grease	Locate fitting and Grease	Semi-annually
●	11. Front/Rear A-arm pivot Shaft	Grease	Locate fitting on pivot shaft and grease with grease gun	Every 3 months or 50 hours
●	12.Throttle Cable	Grease M	Grease, inspect and replace it if necessary	Monthly or 20 hours
●	13. Accelerator pedal and brake pedal	Grease	Grease, inspect	Monthly or 20 hours
●	14.Rear Wheel Bearing	Inspect	Inspect and replace bearings if necessary	Semi-annually

## 16. MAINTENANCE

---

**NOTE:**

1. More often under severe use, such as wet or dusty conditions .
2. Grease: Light weight lithium-soap grease.
3. Grease M : molybdenum disulfide( $\text{MoS}_2$ ) grease(water resistant).
4. \*When suspension action becomes stiff or after washing.
5. Hours are based on 10 mph(16Km/h) average.

## 16. MAINTENANCE

### PERIODIC MAINTENANCE RECORD

Use the following chart to record periodic maintenance work :

Maintenance Interval Performed	Servicing Date	Servicing Dealer or Person	Remarks
First 5 Hrs			
10 Hrs			
15 Hrs			
20 Hrs			
25 Hrs			
50 Hrs			
75 Hrs			
100 Hrs			

The following items should be checked occasionally for tightness; or if they have been loosened for maintenance service.

#### WHEEL NUT TORQUE SPECIFICATIONS

Bolt Size	Specification
Front M10X1.25	63Ft.Lbs 85N.m
Rear M10X1.25	63Ft.Lbs 85N.m

#### Front Wheel Hub Tightening

Front wheel bearing tightness and spindle nut retention are critical

## 16. MAINTENANCE

component operations. Service work must be performed by an authorized dealer.

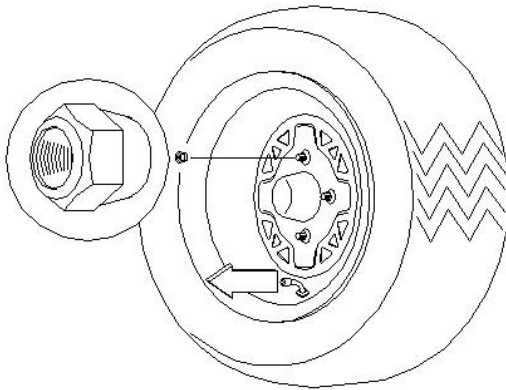

**Front**                      **Rear**  
**Tapered nuts: install with tapered side against wheel**

### AXLE BOOTS

- Rear Prop Shaft Boots,
  - Front Axle (CV Joints, 4x4 model) Boots,
- Check the protective boots for holes or tears. If any damage is found, have them replaced by an authorized dealer.

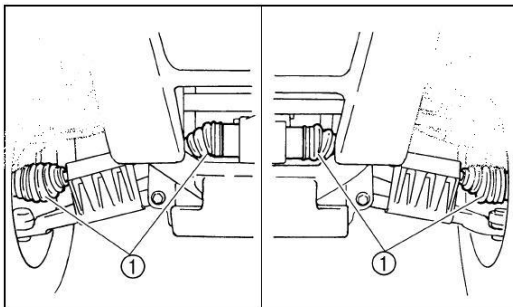

1. Front axle boot (x 2 each side)

### REAR SPRING ADJUSTMENT

The rear shock absorber spring is adjusted by rotating the adjuster in the direction required to increase or decrease spring tension.

Rear Spring

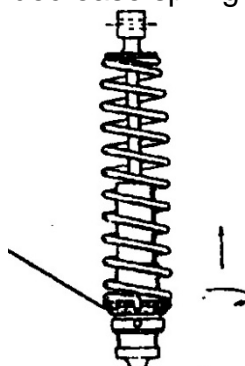



## 16. MAINTENANCE

### Adjustment

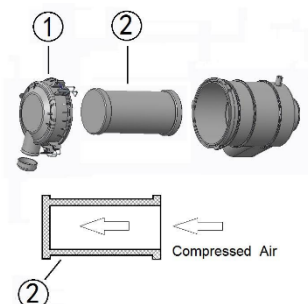
#### AIR FILTER SERVICE



1. Disengage the three cover latches .
2. Unlatch the cover and carefully remove it from the air box.
3. Remove the filter .
4. Inspect the air box for oil or water deposits. Wipe away any deposits with a clean shop towel.  
**Note:** If the filter has been soaked with fuel or oil it must be replaced.
5. Inspect the air filter and replace if necessary.  
**Note:** DO NOT attempt to clean the air filter with compressed air .
6. Place the air filter into the air box and reinstall the air box cover.  
**Note:** Make sure the tabs are properly positioned into the hinge.  
 Ensure the O-ring is installed inside the lid properly.
7. Engage the cover latches.

#### STEERING

##### Steering Inspection

The steering assembly of the machine should be checked periodically for loose nuts and bolts, worn tie rod ends, worn boots, and damage. Checking routing of all cables, hoses, and wiring to be sure the steering mechanism is not restricted or limited. If any found, have your

## 16. MAINTENANCE

dealer repair them before riding your vehicle.

The steering assembly should be also checked periodically for free operation, steering should move freely through entire range of travel without binding. Park on level ground. Turn the steering wheel right and left. Check for excessive free play, abnormal noises, or a rough feeling. Have an authorized dealer repair as necessary for proper operation.

### Lubricate the pivoting parts.

Recommended lubricant:  
Lithium-soap-based grease

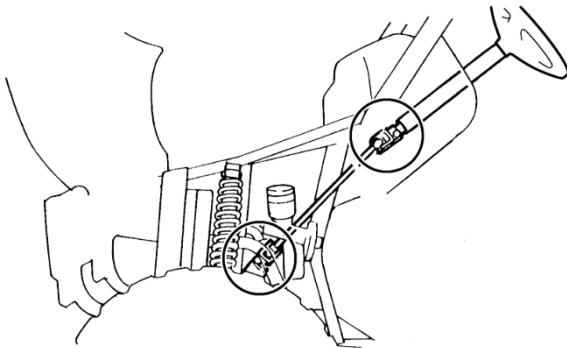

### CAMBER AND CASTER

The camber and caster are non-adjustable.

### TOE ALIGNMENT CHECK



### WARNING

Do not attempt to adjust the tie rod for toe alignment. Severe injury or death can result from improper adjustment. Contact your dealer. He/she has the training and tools to Make these adjustment.

The recommended toe alignment is 1/8" to 1/4" (3 to 6mm) toe out.

1. Set the steering wheel in a straight ahead position and hold them in this position.
2. Measure A and B, A minus B should be 1/16" to 1/8" (1.5 to 3mm).
3. If this measurement needs to be adjusted, contact your dealer for service.

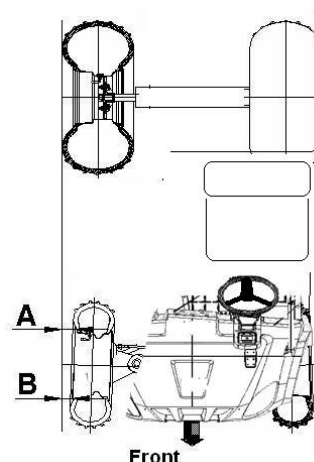

## 16. MAINTENANCE

---



### WARNING

If the tie rod is positioned incorrectly or adjusted incorrectly, it will not pivot, may break, and may separate. Severe injury or death can result

---

Hold Rod End

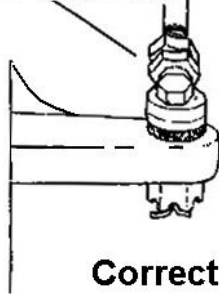

**Correctly  
Tightened  
Jam Nut**

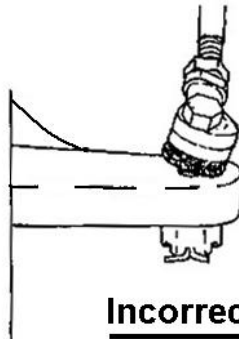

**Incorrectly  
Tightened  
Jam Nut**

**BRAKES**

### Front brake



### WARNING

Once a bottle of brake fluid is opened, use what is necessary and discard the rest. Do not store or use a partial bottle of brake fluid. Brake fluid is hygroscopic, meaning it rapidly absorbs moisture from the air. This causes the boiling temperature of the brake fluid to drop, which can lead to early brake fade and the possibility of serious injury.

---

The front brake is hydraulic disc brakes which is depressing the brake pedal. These brakes are self-adjusting and require no adjustment.

The following checks are recommended to keep the brake system in good operating condition. How often they need checking depends upon the type of driving that has been done.

- Keep fluid level in the master cylinder reservoirs. Normal functioning of the diaphragm is to extend into the reservoir as fluid level drops. If the fluid level is low and the diaphragm is not extended, a leak is indicated and the diaphragm should be replaced. Always fill the reservoir as indicated whenever the cover is loosened or removed to insure proper

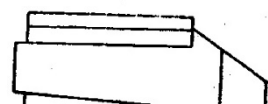

## 16. MAINTENANCE

---

diaphragm operation. Use DOT 3 brake fluid.

- Check brake system for fluid leaks.
- Check brake for excessive travel or spongy feel.
- Check friction pads for wear, damage and loosened.
- Check security and surface condition of the disc.
- Pads should be changed when friction material is worn to 3/64"(1mm).(A)

### Rear Brake

- The rear brake is a hydraulic disc type brake which is activated by the same pedal which activates the front brake system is self adjusting and requires no maintenance other than periodic checks of the pads for wear
- Pads should be changed when the friction material is worn to 3/64"(1mm).
- Inspect the brake disc and pad wear surface for excessive wear.

### Checking the brake fluid level

Insufficient brake fluid may let air enter the brake system, possibly causing the brakes to become ineffective. Before riding, check that the brake fluid is above the minimum level mark and replenish if necessary. A low brake fluid level may indicate worn brake pads and/or brake system leakage. If the brake fluid level is low, be sure to check the brake pads for wear and the brake system for leakage.

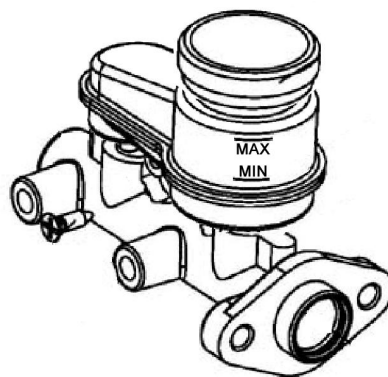

The brake fluid reservoir is located under the hood.

- When checking the fluid level, make sure the top of the brake fluid reservoir is level.
- Use only the recommended quality brake fluid. Otherwise, the rubber seals may deteriorate, causing leakage and poor braking performance.

Recommended brake fluid: DOT 3

- Refill with the same type of brake fluid. Mixing fluids may result in a

## 16. MAINTENANCE

harmful chemical reaction and lead to poor braking performance.

- Be careful that water does not enter the brake fluid reservoir when refilling. Water will significantly lower the boiling point of the fluid and may result in vapor lock.
- Brake fluid may deteriorate painted surfaces or plastic parts. Always clean up spilled fluid immediately.
- Have an authorized dealer inspect the brake system if the brake fluid level goes down.

### Brake pedal and accelerator pedal lubrication

Lubricate the pivoting parts.

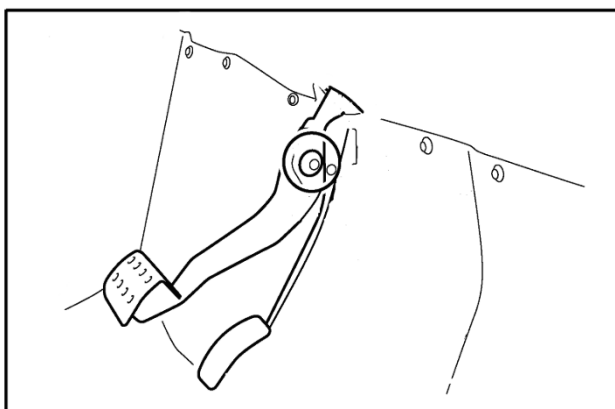

Recommended lubricant:  
Lithium-soap-based  
grease (all-purpose  
grease)

### PARKING BRAKE Checking

Although the parking brake

has been adjusted at the factory, the brake should be checked for proper operation. The mechanical brake must be maintained to be fully functional.

1. With the engine off, apply the parking brake lever and attempt to move the UTV.
2. If the rear wheels are locked, it is adjusted properly.
3. If the wheels are not locked, it must be adjusted.
4. The maximum free play is equal to one click of the parking brake lever. If necessary, adjust the free play as follows.

### Adjusting

**To adjust (set up) the mechanical parking brake, use the following procedure**

**Note:** The adjusting on the caliper is for the wear out of the pads.

1. With the engine off, loosen the adjuster on the lever.
2. Loosen the jam nut of the adjuster on the caliper.
3. Turn the adjuster (bolt) CW (clockwise) by hand till the pad touch the brake disc, turn the adjuster bolt CCW (counterclockwise) by 1/4 to one

## 16. MAINTENANCE

turn for 10 to 20mm free play at the end of the parking lever.

4. Tighten the jam nuts securely against the adjusters.
5. Make sure the rear wheels turns freely without dragging.
6. Turn the adjuster (the one on the lever) and apply the lever. While adjusting, it is important you apply the lever back and forth for operation, free play and the locking of the parking position.
7. Make sure the rear wheels turns freely without dragging and parking brake works properly.



### CAUTION

Don't over tighten the adjuster. The maximum free play is equal to one click of the parking brake lever.

8. Field test for parking. It must be capable of holding the laden UTV stationary on an 20% up and down gradient.

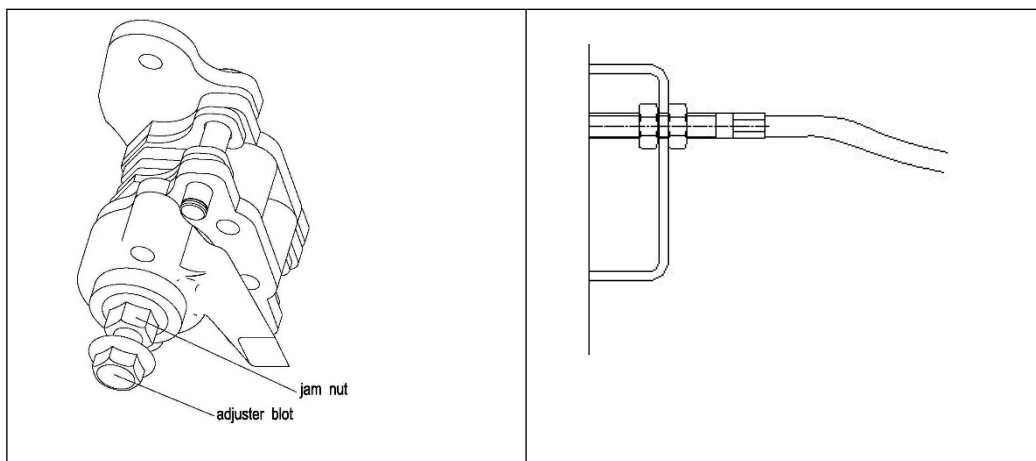

A temporary adjusting can also be done to the brake cable on the parking lever side by turn the adjuster (nut) directly. But the adjust range is limited. Always do the **procedure 1 to 8** when necessary.

### Parking Brake Indicator (light) Switch Adjustment

#### Throttle Free Play Inspection

1. Apply the parking brake.

## 16. MAINTENANCE

---

2. Put gear in Neutral position.
3. Start the engine, and warm it up thoroughly.
4. Measure the distance the throttle pedal moves before the engine begins to pick up seep. Free play should be 1/16" to 1/8" (1.5-3mm).

### SPARK PLUGS

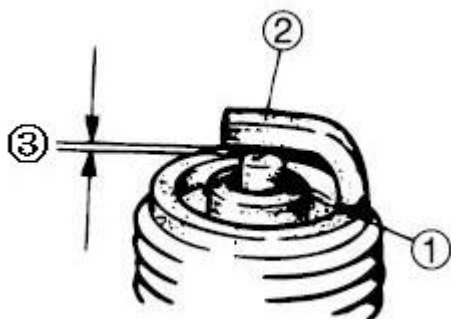

Standard spark plug  
DPR8EA-9(NGK)

③ Gap:0.8-0.9mm

Inspect:

- Insulator ①  
Abnormal color: Replace.  
Normal color is a medium-  
To-light tan color.
- Electrode ②  
Wear/damage: Replace. Clean:
- Spark plug  
(with spark plug cleaner or wire  
brush)

Measure:

- Spark plug gap ③  
Out of specification: Adjust gap.

### Spark Plug Removal and Replacement



#### WARNING

Never attempt to remove a spark plug while the engine is warm. The exhaust system or engine could burn you causing severe injury.

---

Remove the spark plug by rotating counterclockwise.

Reverse the procedure for spark plug installation.

Torque to 17ft.lbs (23N.m).

### OIL AND FILTER CHANGE

The recommended oil change interval is 30 hours, or every 3 months, whichever comes first. Suggested break in oil change is at 20 hours, or one month, whichever comes first. Severe use operation requires more frequent service. Severe use includes continuous duty in dusty or wet

## 16. MAINTENANCE

---

conditions, and cold weather riding.

**NOTE:** Severe use cold weather riding is all riding below 10°F(-12°C), and riding between 10°F (-12°C) and 30°F (0°C) when most trips are slow speed and less than 5 mph (8km/h). Be sure to change the oil filter whenever changing oil



### CAUTION

Oil may be hot. Do not allow hot oil to come into contact with skin as severe burns may result

---

1.

Place vehicle on a level surface;

2. Run engine two or three minutes until warm, Stop engine;
3. Clean area around drain plug;
4. Place a drain pan beneath engine crankcase and remove drain plug;
5. Allow oil to drain completely;
6. Reinstall drain plug and torque to 18ft.lbs (25N.m)

### Rear Gearcase Lubrication



### CAUTION

Be sure no foreign material enters the gear case.

With the UTV on a level surface, remove fill plug and visually inspect the lubricant level through the fill hole. Lubricant should be kept even with the center of the drill point approximately below the top of the fill hole.

**NOTE:** Do not add lubricant to the bottom of the fill plug threads. The correct gearcase lubricant to use is SAE GL-4 85W/90 Weight Gear Lube.

## 16. MAINTENANCE

---

### Oil Changing Procedure

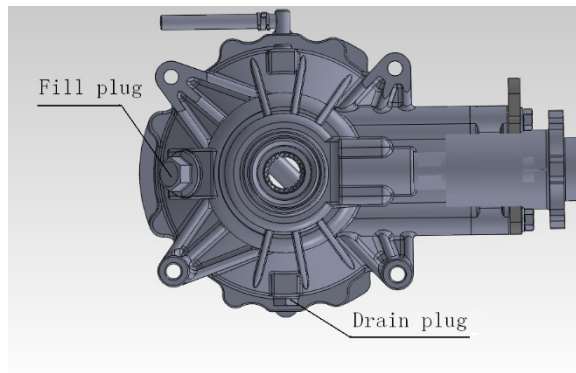

1. Remove the drain plug. Catch and discard used oil properly.
2. Clean and reinstall the drain plug with a new sealing washer and tighten securely (11~15ft. lbs/15~20N.m).
3. Remove the fill plug and add 10 ounces (300ml) of SAE GL-4 85W/90 Weight Gear Lubricant and inspect oil level. Oil level should be kept even with the center of the drill point (approximately below the top of the fill hole).
4. Reinstall the fill plug. Tight securely (26~30 ft. lbs/35~40N.m).
5. Check for leaks.

### Front Gearcase Lubrication



#### **CAUTION**

Be sure no foreign material enters the gear case.

With the ATV on a level surface, remove fill plug and visually inspect the lubricant level through the fill hole. Lubricant should be kept even with the center of the drill point approximately below the top of the fill hole.

NOTE: Do not add lubricant to the bottom of the fill plug threads. The correct gear case lubricant to use is SAE GL-4 85W/90 Weight Gear Lube.

## 16. MAINTENANCE

---

### Oil Changing Procedure

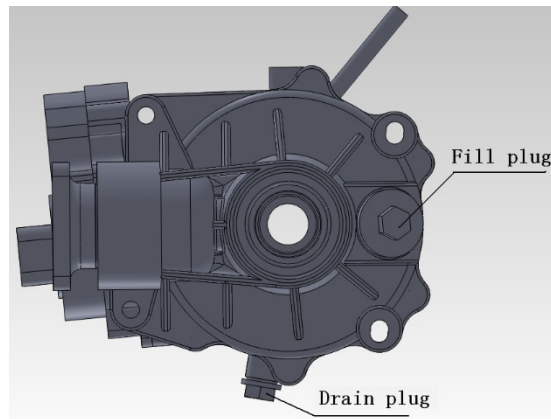

1. Remove the drain plug. Catch and discard used oil properly.
2. Clean and reinstall the drain plug with a new sealing washer and tighten securely (14.8 ft. lbs/20N.m).
3. Remove the fill plug and add 7-8.5 ounces (200ml-250ml) of SAE GL-4 85W/90 Weight Gear Lubricant and inspect oil level. Oil level should be kept even with the center of the drill point (approximately below the top of the fill hole).
4. Reinstall the fill plug. Tight securely (18.4 ft. lbs/25N.m).
5. Check for leaks.

### WHEELS AND TIRES



#### WARNING

Operating your UTV with worn tires, improperly inflated tires, non-standard tires or improperly installed tire will affect vehicle handling which could cause an accident resulting in serious injury or death. Follow the safeguards listed below to prevent this type of situation.

#### Important Safeguards

Maintain proper tire pressure according to charts below. Improper tire inflation may affect UTV maneuverability.

Do not use improper tires. The use of non-standard size or type tires

## 16. MAINTENANCE

---

may affect UTV handling.

Make certain the wheels are installed properly. If wheels are improperly installed it could affect vehicle handling and tire wear.

Tire Pressure	
front	rear
see detail on the mark of sidewall	see detail on the mark of sidewall

### Wheel Removal Procedure

1. Stop the engine, place the transmission in gear and lock the parking brake.
2. Loosen the wheel nuts slightly.
3. Elevate the side of the vehicle by placing a suitable stand under the footrest frame.
4. Remove the wheel nuts and remove the wheel.

### Wheel Installation

1. With the transmission in gear and the parking brake locked, place the wheel in the correct position on the wheel hub. Be sure the valve stem is toward the outside and rotation arrows on the tire point toward forward rotation.
2. Attach the wheel nuts and finger tighten them.
3. Lower the vehicle to the ground.
4. Securely tighten the wheel nuts according to the chart found in "**16.MAINTENANCE/ Wheel Nut Torque**".

### Tire Inspection

When replacing a tire always use original equipment size and type.

## 16. MAINTENANCE

### Tire Tread Depth

Always replace tires when tread depth is worn to 1/8" (3mm) (1) or less. Please refer to your Owner's Manual for tire specifications.

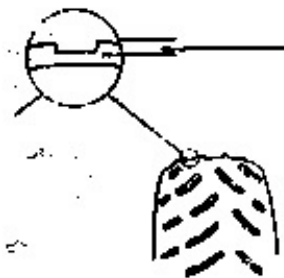

### LIGHTS



#### WARNING

Keep your headlights and taillights clean. Poor light while riding can result in an accident causing severe injury or death.



#### CAUTION

Do not service while headlight is hot. Serious burns may result. Do not touch a halogen lamp with bare fingers. Oil from your skin leaves a residue, causing a hot spot which will shorten the life of the lamp.

### Headlight Lamp Replacement and Adjust

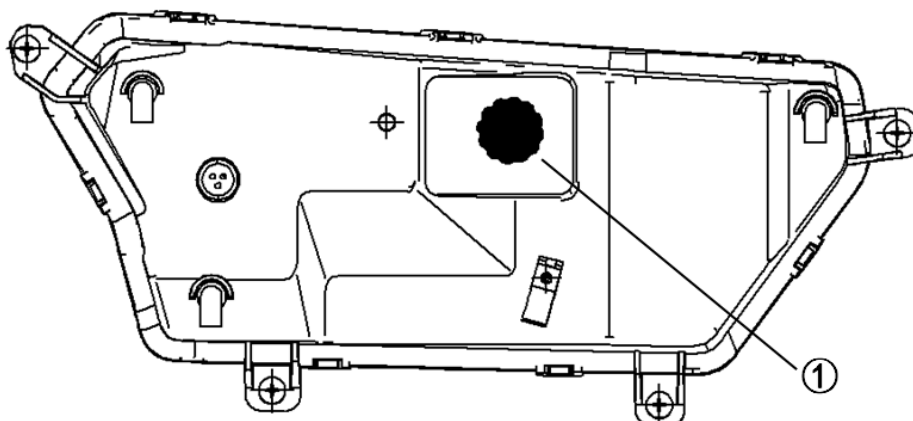

1. To lower headlight brightness cut-off line, turn adjusting bolt ① counterclockwise. And to raise brightness cut-off line, turn the bolt clockwise.

## 16. MAINTENANCE

2. This type of headlight is LED , do not try to replace the bulb, if there is a problem with the headlight, please contact the dealer.

### Taillight / Brake light Lamp Replacement

If the Taillight / Brake light does not work ,the lamp may need to be replaced.

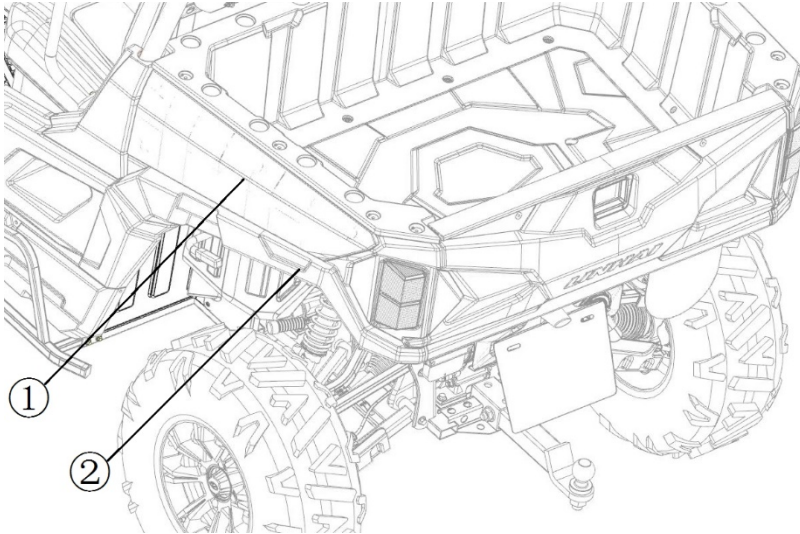

1. Remove the Side Cover A ①.
2. Remove the Side Cover B ②.

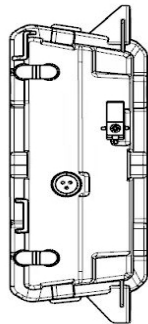

3. Take off the Taillight / Brake Light.
4. Test the new Taillight/ Brake Light to see that it's working .
5. Re-install the Light .

## 16. MAINTENANCE

---

### CLEANING YOUR UTV

Keeping your UTV clean will extend the life of various components.

#### WASHING

Never use a high pressure type car wash system, it can damage to the wheel bearings, transmission seals, body panels, brakes and warning labels, and water might enter the engine or exhaust system.

The best and safest way to clean your UTV is with a garden hose and a pail of mild soap and water. Use a professional type washing mitten, cleaning the upper body first and lower parts last. Rinse with water frequently and dry with a chamois to prevent water spots. **NOTE:** If warning labels are damaged, contact your dealer for replacement.

#### WAXING

Your UTV can be waxed with any non-abrasive automotive paste wax. Avoid the use of harsh cleaners since they can scratch the body finish.



### CAUTION

Certain products, including insect repellants and chemicals, will damage plastic surfaces. Care must be taken when using these products plastic surfaces.

### STORAGE TIPS



### CAUTION

Do not start the engine during the storage period. This will disturb the protective film created by fogging.

**Cleaning**—Clean the UTV thoroughly.

**Fuel**—To avoid possible fire, drain the fuel tank for long-term storage. However, when starting the UTV again, ensure that there is enough fuel in the fuel tank ( The fuel gauge indicator is more than one grid ).

**Oil Add and Filter Change**—Warm the engine and change oil and filter.

**Air Filter/Air Box**—Inspect and clean or replace the pre-cleaner and air filter. Clean the air box and drain the sediment tube.

**Inspect All Fluid Levels**—Inspect the following fluid levels and change if necessary: transmission; brake fluid (change every two years or as required if fluid looks dark or contaminated).

**Fog the Engine**—Spray a light oil into the cylinder through the spark

## 16. MAINTENANCE

---

plug hole.

**Check and Lubricate Cables/Grease**—Inspect all cables and lubricate.

**Battery Maintenance**—Remove the battery and store in a dry place. Apply Dielectric Grease to the terminal bolts and terminals. Often charge the battery.

**Storage Area/Covers**—Set tire pressure and safely support the UTV with the tires 1-2"(25-50mm) off the ground. Be sure the storage area is well ventilated. Cover the machine with a UTV cover.

NOTE: Do not use plastic or coated materials. They do not allow enough ventilation to prevent condensation, and may promote corrosion and oxidation.

### TRANSPORTING

Whenever the UTV is to be transported the following measures should be taken.

1. Turn off the engine and remove the key.
2. Be certain the fuel cap, oil cap, and seat are installed correctly.
3. Always tie the frame of the UTV to the transporting until securely using suitable straps or rope.
4. Always place the transmission in gear and lock the parking brake.

## 17. TROUBLESHOOTING

### Issues of Improper Operation Driven Clutch (CVT) Burning

Possible Causes	Solutions
Loading the UTV into a pickup or tall trailer when in high range.	Shift transmission to Low Range during loading of the UTV to prevent belt burning
Starting out going up a steep incline	When starting out on an incline, use low range. When parking, first applying the park brake and perform the "K" turn, then dismount the UTV.
Driving at low RPM or low ground speed (at approximately 3-7MPH/ 5-12km/h)	Drive at higher speed or use low range. The use of low range is highly recommended for cooler CVT operating temperatures and longer component life.
Insufficient warm-up of UTV's exposed to low ambient temperatures.	Warm engine at least 5 min., they with transmission in neutral, advance throttle to approx. 1/8throttle in short bursts, 5 to 7 times. The belt will become more flexible and prevent belt burning.
Slow and easy clutch engagement.	Fast, effective use of the throttle for efficient engagement.
Towing /Pushing at low RPM/low ground aped.	Use Low Range only.
Stuck in mud or snow.	Shift the transmission to Low Range carefully use fast, aggressive throttle application to engage clutch. WARNING: Excessive throttle may cause loss of control and vehicle overturn.
Climbing over large objects from a stopped position.	Shift the transmission to Low Range carefully use fast, brief, aggressive throttle application to engage clutch. WARNING: Excessive throttle may cause loss of control and vehicle overturn.

### Low Battery

Possible Cause	Solutions
Starting a faulty engine for long time	See"8.STARTING THE ENGINE" And check the fuel/ air/ ignition/ compression system
Let the main switch (key) on while parking the UTV	When stopping the engine, turn off the main switch (key) off at once

## 17. TROUBLESHOOTING

---



### WARNING

**This UTV is equipped with EFI system ,If the battery is under 12 Volt, the engine will not start.**

---

#### NOTE:

The following trouble shooting does not cover all the possible causes of trouble. It should be helpful, however, as a guide to troubleshooting. Refer to the relative procedure in this manual for inspection, adjustment and replacement of parts. Adjustment and replacement must be done by your dealer.

---

### STARTING FAILURE / HARD STARTING

#### FUEL SYSTEM

##### Fuel tank

- Empty
- Clogged fuel tank breather pipe
- Deteriorated fuel or fuel containing water or foreign material
- fuel filter clogging
- the fuel pressure not correct

##### Throttle body

- The connect not good

##### Air cleaner

- Clogged air cleaner element
- Improper air cleaner setting

#### COMPRESSION SYSTEM

##### Cylinder and cylinder head

- Loose spark plug
- Loose cylinder head
- Broken cylinder head gasket
- Broken cylinder gasket
- Worn, damaged or seized cylinder

##### Valve system

- Improperly adjusted valve clearance
- Improperly sealed valve
- Improperly contacted valve and vale seat
- Improper valve timing
- Broken valve spring
- Seized valve

##### Piston and Piston ring

- Worn piston
- Worn fatigued or broken piston ring
- Seized piston ring
- Seized or damaged piston

## 17. TROUBLESHOOTING

---

### IGNITION SYSTEM

#### Battery

- Improperly charged battery
- Faulty battery

#### Fuse

- Burnt out, improper connection

#### Spark plug

- Improper plug gap
- Worn electrodes
- Wire between terminals broken
- Improper heat range
- Faulty spark plug cap

#### Ignition coil

- Broken or shorted primary/secondary coil
- Faulty high tension cord
- Broken ignition coil body

#### Ignition system

- Faulty ignitor unit
- Faulty pick up coil
- Broken magneto woodruff key

#### Switch

- Faulty main switch
- Faulty "ENGINE STOP" switch
- Faulty brake switch

#### Wiring

- Loose battery terminal
- Loose coupler connection
- Improperly grounded
- Broken wireharness

---

### POOR IDLE SPEED PERFORMANCE

#### EFI

- the fuel pressure not correct
- fuel filter clogging
- fuel injector clogging

#### Valve system

- Improperly adjusted
- valve clearance

#### Air cleaner

- Clogged air cleaner element

#### Ignition system

- Faulty spark plug
- Faulty high tension cord
- Faulty ignitor unit
- Faulty pick up coil
- Faulty ignition coil

---

### POOR MEDIUM AND HIGH SPEED PERFORMANCE

#### Air cleaner

- Clogged air cleaner element

#### EFI

- the fuel pressure not correct
- fuel filter clogging
- fuel injector clogging

## 17. TROUBLESHOOTING

---

### POOR SPEED PERFORMANCE

#### Ignition system

- Dirty spark plug
- Improper heat range
- Faulty igniter unit
- Faulty pick up coil

#### Fuel system

- Clogged fuel tank breather hole
- Clogged air cleaner element
- fuel filter clogging
- the fuel pressure not correct

#### Engine oil

- Improper oil level (low or over Oil level)

#### Valve system

- Improperly adjusted valve clearance

#### Compression system

- Worn cylinder
- Worn or seized piston ring
- Cylinder head gasket broken
- Cylinder gasket broken
- Carbon deposit buildup
- Improper adjusted valve clearance
- Improper contacted valve and valve seat
- Faulty valve timing

#### Clutch

- Refer to "CLUTCH SLIPPING /DRAGGING" section

#### Ignition system

- Faulty spark plug
- Faulty high tension cord
- Faulty ignitor unit
- Faulty pick up coil
- Faulty ignition coil

---

### OVER HEATING OR OVER-COOLING

#### OVER HEATING

##### Ignition system

- Improperly spark plug gap
- Improper spark plug heat rang
- Faulty igniter unit

##### Compression system

- Heavy carbon deposit build-up
- Improperly adjusted valve timing
- Improperly adjusted valve clearance

#### OVER-COOLING

##### Cooling system

- Faulty thermostat
- Faulty thermo switch

## 17. TROUBLESHOOTING

---

### Engine oil

- Incorrect engine oil level
- Improper engine oil quality (High viscosity)
- Low engine oil quality

### Brakes

- Dragging brake

### Cooling system

- Inoperative fan motor
  - Faulty thermostat
  - Faulty thermo switch
  - Incorrect coolant level (low coolant level)
  - Faulty radiator (Clogged, damage)
  - Faulty radiator cap
  - Impeller shaft gear malfunction (bent dowel pin, gear)
  - Damaged impeller shaft
  - Disconnected fan motor connector
- 

### FAULTY CLUTCH

#### WHEN ENGINE RUN, UTV DOES NOT RUN

##### V belt

- Worn/bent/slipping

##### Cam, slider

- Worm/damaged

##### Compression spring

- Damage

##### Gears

- Damage

#### POOR SPEED PERFORMANCE

##### V-belt

- Worn
- Oil V belt

##### Roller weight

- Worn/improper operation primary/secondary/sheave
- Worm

## 17. TROUBLESHOOTING

---

### CLUTCH SLIPPING

#### Clutch weight spring

- Worn/loose

#### Clutch shoe

- Worn/ damaged

#### Primary sliding sheave

- Seized

### POORSTARTING

#### PERFORMANCE

##### V-belt

- Worn front hub bearing
- Slipping/oily V-belt

##### Primary sliding sheave

- Improper operation
- Damage

##### Compressing spring

- Worm/loose

##### Secondary sliding sheave

- Improper operation
- Worn guide pin grove
- Worn guide pin

##### Clutch shoe

- Worn/ bent

### CVT SYSTEM

#### Uncorrect Primaty Clutch Position

- Uncorrect engine mount  
(see 13. CVT system)

### FAULTY BRAKE

#### POOR BRAKING EFFECT

- Worn brake pad
- Worn brake disc
- Air in brake fluid
- Leaking brake fluid
- Faulty master cylinder kit
- Faulty caliper seal kit
- Loose union bolt
- Broken brake hose
- Oily or greasy brake pad
- Oily or greasy brake disc

## 18. TOOL

---

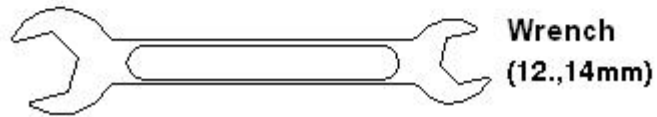
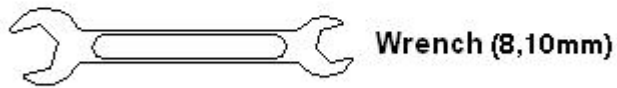
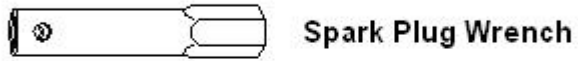
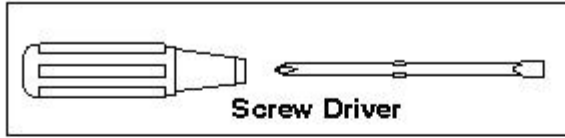

## 19. SPECIFICATION

<b>Dimensions &amp; Capacities</b>			
L X W X H	2735×1465×1883 mm		108×58×74 in
Seat height	869 mm		34.2 in
Wheel Base	1883 mm		74 in
Turn Radius	Outer: 4500 mm		177 in
	Inner: 3000 mm		118 in
Ground Clearance	286 mm		11 in
Fuel capacity	26 L		6.87 US gal
Engine Oil Capacity	2.2L		0.58 US gal
Dry Weight	570 kg		1257 lb
Cargo Bed Maximum load limit	150 kg		331 lb
Load Capacity (Combined Rider& Payload)	300 kg		661 lb
Gross Vehicle Weight (Maximum Technically Permissible Mass)	885 kg		1951 lb
Tongue Weight	10 kg		22 lb
Tow Capacity	200 kg		441 lb
<b>Drive System</b>			
Drive System	CVT		
Front Tire	27X9-14		
Rear Tire	27X11-14		
Tire Pressure(front)	See detail on the mark of sidewall		
Tire Pressure(rear)	See detail on the mark of sidewall		
<b>Brake System</b>			
Brake	Front Brake	Dual Hydraulic Disc	Front and rear unified
	Rear Brake		
	Operation	Foot	
Parking Brake	Mechanical Disc		
<b>Suspension</b>			
Front	Twin-A arm independent suspension		
Rear	Twin-A arm independent suspension		
shock absorber	Coil spring/oil damper		

## 19. SPECIFICATION

<b>Engine</b>	
Engine Type	LH191MS-C 4Stroke, Single Cylinder, SOHC
Bore x Stroke	91mmX90mm
Displacement	585.3cc
Starter System	Electric Starter
Engine Cooling	Liquid-Cooled
Lubrication System	Wet Sump
Ignitions	ECU
Spark Plug Type	DPR8EA-9 ( NGK)

<b>Electrical Equipment</b>			
Battery		12V 18Ah (12V 30Ah FOR EPS MODEL)	
Head light		LED	
Brake/ Tail Light		LED	
Front Position Light		LED	
Specified fuses	Main Fuse	30 A	On The Start Relay
	Backup Fuse	30 A	
	LAMP Fuse	10 A	
	12V DC Fuse	15 A	In The Fuse Box
	SIGNAL Fuse	15 A	
	ECU1 Fuse	25A	
	ECU2 Fuse	5A	
	FAN Fuse	10A	
	REAR DIFF LOCK Fuse	20A	
	EPS Fuse	30A	
	SPARE Fuse	10A	
	SPARE Fuse	15A	