



SHARK[®]
PROFESSIONAL ACCESSORIES

SHARK GARDEN 150 ATV trailer Assembly and usage instructions



CONTENTS:

Safety warnings	2
Assembling the trailer	2
Use, maintenance, storage	3
Technical data	3
List of parts	4

Dear Customer!

Thank you for choosing a product from the Shark Accessories professional accessories range. We trust that you will be satisfied with this product for many years to come.

WARNING

IMPORTANT: This user manual contains information that is important for the safety of persons and the protection of property.

Before using the trolley, read this entire manual and familiarise yourself with the location and function of the controls!

CONTENTS:

Safety warning	5
Trolley assembly	5
Use, maintenance, storage	6
Technical data	6
List of parts	4

Dear Customer!

Thank you for choosing a product from the Shark Accessories professional accessories range. We trust that you will be satisfied with this product for a long time to come.

WARNING

IMPORTANT: This user manual contains information that is important for the safety of persons and the protection of property.

Before using the trolley, read this entire manual and familiarise yourself with the location and function of the controls!

CZ - ASSEMBLY AND USER MANUAL

SAFETY WARNING

- When taking delivery of the trolley, please check that no parts are missing and that no components have been damaged during transport.
- Never transport seated or standing persons or animals on the trolley.
- Do not allow children to play on, climb on or climb over the trolley.
- Before driving, always ensure that the trolley is in good technical condition.
- Replace damaged or worn parts immediately with new ones.
- Always check that all bolts, nuts and connecting parts are tight before riding.
- Never exceed the maximum load capacity of the trolley, which is 150 kg.
- When riding with a loaded trolley, avoid dangerous areas, potholes, uneven terrain or steep slopes where the trolley could tip over.
- Always drive slowly and carefully on rough terrain, hills and slippery surfaces.
- Do not drive the trolley into water, over deep ditches or on public roads.
- Prevent injury to persons and/or damage to the trolley – do not exceed a speed of 25 km/h.
- Be careful when loading and unloading the trailer.
- The trailer is only intended to be towed by suitable vehicles (garden tractor, quad bike, UTV).
- Before driving, properly connect and secure the trailer to the towing vehicle's coupling device.
- Always keep your hands and feet away from moving parts while driving and working.
- Always keep the working area around the trailer clean when working.
- Always wear protective equipment, such as safety glasses and work boots, when working with the trolley.

ASSEMBLING THE TROLLEY

- This trolley is delivered unassembled and must be assembled before use.
- Remove the parts from the packaging and check them against the parts list before starting assembly.
- First, assemble the drawbar (6) with the latch (7) and insert the wheel axle (9) into the hole at the end of the drawbar.
- Attach both chassis parts (3) to the assembly, centre the wheel axle and then screw it tightly into place.
- Fit the wheels (2) – insert the washers on both sides of the wheel hub as shown in the diagram and secure with a cotter pin.
- Now slide the foam sleeve (12) onto the middle part of the handle (10) and assemble the handle with the left (11) and right (13) parts.
- Attach the front leg (8) together with the assembled handle to the body (1).
- Attach the chassis (3) to the trolley body.
- Assemble the drawbar extension (4) with the hitch (5) and swivel wheel (14).
- Insert the extension into the drawbar and secure it with a screw and pin with a cotter pin.
- Tighten all screws and nuts. This completes the assembly.

WARNING

The warnings, cautions and instructions in this manual cannot cover all possible situations that may occur. Therefore, it is necessary to always use common sense when working and to exercise extreme caution when working and driving.

USE, MAINTENANCE, STORAGE

TILTING THE BODY

To tilt the body, release the safety latch and carefully tilt the body backwards.

Before driving, secure the body again with the safety latch to prevent accidental tipping during driving.

USE AS A CLASSIC MANUAL GARDEN "WHEELBARROW" WITHOUT A TOWING VEHICLE

Loosen the pin and turn the drawbar extension so that the swivel wheel points downwards.

Secure both parts again with the pin. The trolley can now be easily manoeuvred using the third wheel.

MAINTENANCE AND STORAGE

- After each use, clean the trolley of any residue from the transported materials.
- After each use, clean the trolley inside and out of mud and hardened dirt.
- Check the tyre pressure before driving. The recommended tyre pressure is 200 kPa.
- Lubricate the swing axles and wheel bearings regularly, more often if necessary.
- Regularly check that screw connections are tight.
- Clean and lightly lubricate all mechanisms of the trolley once a year.
- If necessary, repair damaged painted areas with a suitable spray paint.
- Before storing, make sure that the trolley is clean and dry.
- During rainy and winter months, store the trolley in a covered area or in such a way that it is protected from the weather.

Technical data

- Load capacity 150 kg
- Weight: 35 kg
- Dimensions: 157 x 93 x 72 cm
- Body dimensions: 119 x 93 x 30 cm
- Tyres: 16x4-8
- Tyre pressure: 200 kPa

DESCRIPTION OF THE MAIN PARTS OF THE TROLLEY

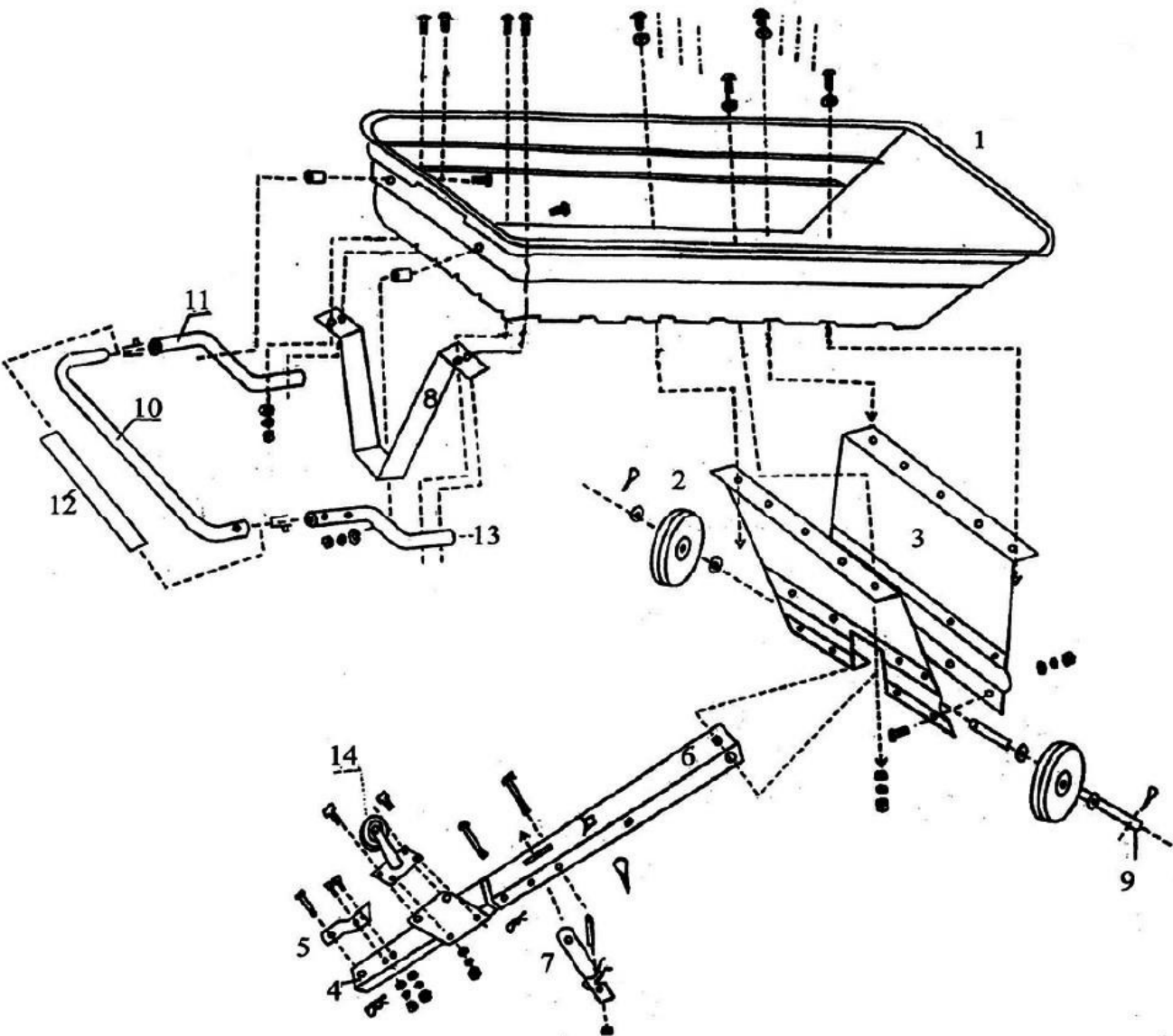

CZ - Main parts of the trolley:			
1	Body	8	Front leg of the body
2	Wheel	9	Wheel axle
3	Chassis	10	Middle part of the handle
4	Drawbar extension	11	Left part of the handle
5	Hinge	12	Foam handle cover
6	Drawbar	13	Right part of the handle
7	Latch	14	Swivel wheel

SK - Main parts of the trolley:			
1	Body	8	Front leg of the body
2	Wheel	9	Wheel axle
3	Chassis	10	Middle part of the handle
4	Extension of the shaft	11	Left part of the handle
5	Hinge	12	Foam handle cover
6	Drawbar	13	Right part of the handle
7	Latch	14	Swivel wheel

SK - ASSEMBLY AND USE INSTRUCTIONS

SAFETY WARNING

- When taking delivery of the trolley, please check that no parts are missing and that no parts have been damaged during transport.
- Never transport seated or standing persons or animals on the trolley.
- Do not allow children to play on, climb on or climb over the trolley.
- Always ensure that the trolley is in good working order before use.
- Replace damaged or worn parts immediately with new ones or repair them.
- Always check that screws, nuts and connecting parts are tight before driving.
- Never exceed the maximum load capacity of the trolley, which is 150 kg.
- When driving with a loaded trolley, avoid dangerous areas, depressions, terrain breaks or steep slopes where the trolley could tip over.
- Always drive very slowly and carefully on difficult terrain, hills and slippery surfaces.
- Do not drive the trolley into water, over deep ditches or on public roads.
- To prevent injury to persons and/or damage to the trolley, do not exceed a speed of 25 km/h.
- Be careful when loading and unloading the trailer.
- The trailer is designed to be towed only by suitable vehicles (garden tractor, quad bike, UTV).
- Before driving, properly connect and secure the trailer to the towing vehicle's coupling device.
- Always keep your hands and feet away from moving parts while driving and working.
- Always keep the working area around the trailer clean when working.
- Always wear protective equipment, such as goggles and work boots, when working with the trailer.

STOPPING THE TRAILER

- This trolley is delivered unassembled and must be assembled before use.
- Remove the parts from the packaging and check them against the parts list before starting assembly.
-
- First, assemble the drawbar (6) with the latch (7) and insert the wheel axle (9) into the hole at the end of the drawbar.
- Attach both chassis parts (3) to the assembly, centre the wheel axle and then screw it tight.
- fit the wheels (2) - insert the washers on both sides of the wheel hub as shown in the diagram, secure with a cotter pin.
- Now slide the foam sleeve (12) onto the middle part of the handle (10) and assemble the handle with the left (11) and right (13) parts.
- Attach the front leg (8) together with the assembled handle to the body (1).
- Attach the chassis (3) to the pram body.
- Assemble the extension of the shaft (4) with the hitch (5) and the swivel wheel (14).
- Insert the extension into the drawbar and secure it with a screw and pin with a cotter pin.
- Tighten all screws and nuts. This completes the assembly.

WARNING

The warnings, cautions, and instructions in this manual cannot cover all possible situations that may occur. Therefore, it is necessary to always use common sense and exercise caution when working and driving.

SK- USE, MAINTENANCE, STORAGE

TILTING THE BODY

To fold the body, release the safety latch and carefully tilt the body backwards.

Before driving, secure the body again with the safety latch to prevent accidental tipping during driving.

USE AS A CLASSIC MANUAL GARDEN "WHEELBARROW"

Release the pin and turn the extension shaft so that the swivel wheel points downwards.

Secure both parts again with the pin. Now you can easily manoeuvre the trolley using the third wheel.

MAINTENANCE AND STORAGE

- After each use, clean the trolley of any residue from the transported materials.
- After each use, clean the trolley inside and out of mud and hardened dirt.
- Check the tyre pressure before driving. The recommended tyre pressure is 200 kPa.
- Lubricate the swing axles and wheel bearings regularly, more often if necessary.
- Regularly check the tightness of screw connections.
- Clean and lightly lubricate all mechanisms of the trolley once a year.
- If necessary, repair damaged painted areas with a suitable spray paint.
- Before storing, make sure that the trolley is clean and dry.
- During rainy and winter months, store the trolley in a covered area or in such a way that it is protected from the weather.

Technical data

- Load capacity 150 kg
- Weight: 35 kg
- Dimensions: 157 x 93 x 72 cm
- Body dimensions: 119 x 93 x 30 cm
- Tyres: 16x4-8
- Tyre pressure: 200 kPa